

# MINOR SUBDIVISION

~for~ **DICK AND MAUREEN BENNETT**  
 (763)-245-9590  
 ~of~ 9337 and 9411 Joliet Ave

## EXISTING LEGAL DESCRIPTIONS:

(Per Washington County Tax Descriptions)

### 9337 JOLIET AVENUE (PID: 15-030-21-41-0004):

The South 300 feet of the North 960 feet of the West 726 feet of the Northeast Quarter of the Southeast Quarter of Section 15, Township 30, Range 21, Washington County, Minnesota.

### 9411 JOLIET AVENUE (PID: 15-030-21-41-0002):

The North 560 feet of the Northeast Quarter of the Southeast Quarter of Section 15, Township 30, Range 21, Washington County, Minnesota.

### UNASSIGNED ADDRESS (PID: 15-030-21-41-0005):

That part of the East half of the Southeast Quarter of Section 15, Township 30, Range 21, Washington County, Minnesota, lying northerly of State Highway No. 96.

EXCEPT

The North 660 feet thereof.

ALSO EXCEPT

The South 300 feet of the North 960 feet of the West 726 feet thereof.

## PROPOSED LEGAL DESCRIPTIONS:

### PARCEL A:

That part of the West 726 feet of the East Half of the Southeast Quarter of Section 15, Township 30, Range 21, Washington County, Minnesota, lying south of the North 660 feet thereof and lying North of State Highway No. 96.

### PARCEL B:

That part of the East half of the Southeast Quarter of Section 15, Township 30, Range 21, Washington County, Minnesota, lying North of State Highway No. 96.

EXCEPT

That part of the West 726 feet of said East Half lying south of the North 660 feet of said East Half.

## NOTES

- Field survey was completed by E.G. Rud and Sons, Inc. on 4/24/18 and 07/01/20.
- Bearings shown are on Washington County datum.
- Curb shots are taken at the top and back of curb.
- This survey was prepared without the benefit of title work. Additional easements, restrictions and/or encumbrances may exist other than those shown hereon. Survey subject to revision upon receipt of a current title commitment or an attorney's title opinion.
- Contours are shown through a combination of LIDAR mapping and field survey data.
- Parcel ID Numbers:

15-030-21-41-0002 (9411 Joliet Ave)  
 15-030-21-41-0004 (9337 Joliet Ave)  
 15-030-21-41-0005 (Unassigned Address)

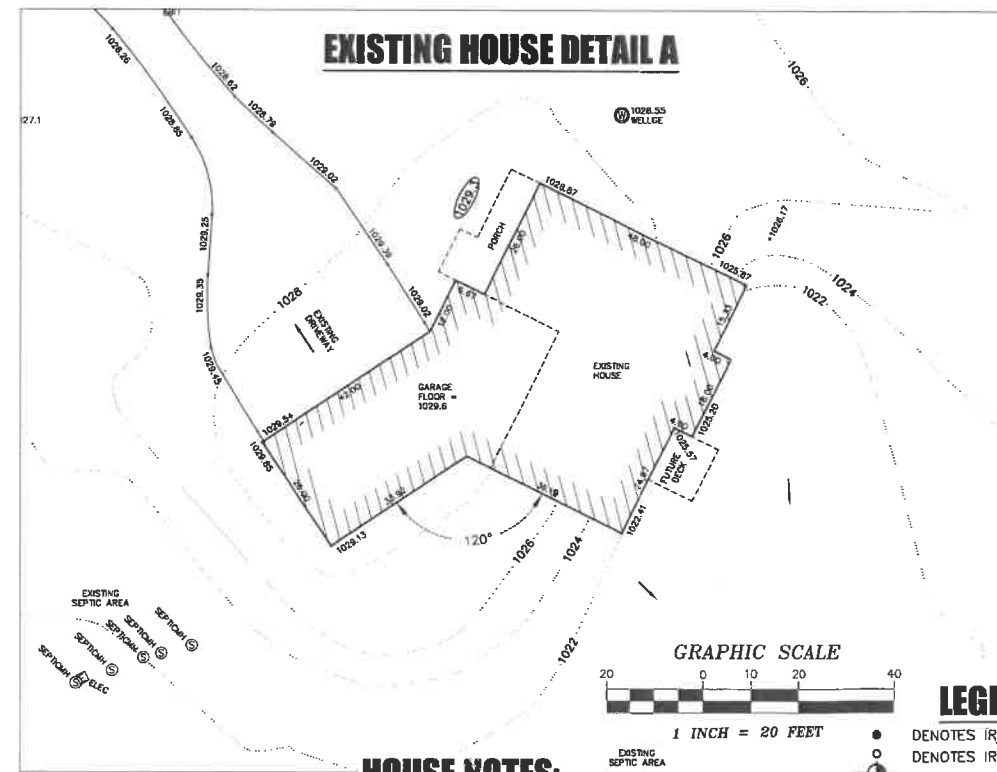
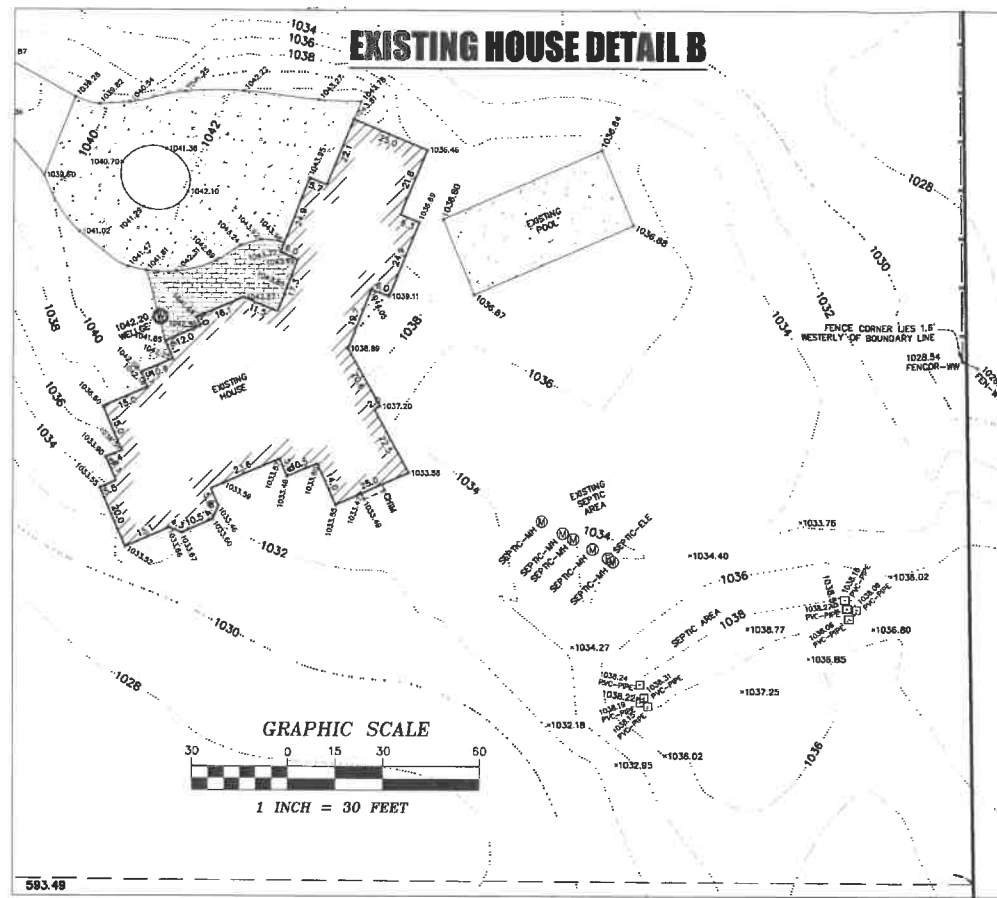

## HOUSE NOTES:

- BUILDER TO VERIFY HOUSE DIMENSIONS, SEWER DEPTH AND FOUNDATION DEPTH. DRIVEWAYS ARE SHOWN FOR GRAPHIC PURPOSES ONLY. FINAL DRIVEWAY DESIGN AND LOCATION TO BE DETERMINED BY CONTRACTOR.
- FINISHED GRADE ADJACENT TO HOME SHALL BE 0.5 FEET BELOW TOP OF BLOCK EXCEPT AT DRIVEWAY AND PATIO.

DIAGONAL (GARAGE): 33.92 X 48.00 = 56.77  
 (8 FOOT POURED WALL WALKOUT)

### PROPOSED ELEVATIONS:

TOP OF WALL = 1030.0  
 GARAGE FLOOR = 1029.5  
 LOWEST FLOOR = 1022.5  
 TOP OF FOOTING = 1022.0

## LEGEND

- DENOTES IRON MONUMENT FOUND AS LABELED
- DENOTES IRON MONUMENT SET, MARKED RLS# 41578
- ⊙ DENOTES WASHINGTON COUNTY CAST IRON MONUMENT
- ⊕ DENOTES ELECTRICAL MANHOLE
- ⊖ DENOTES MISCELLANEOUS MANHOLE
- ⊗ DENOTES POWER POLE
- ⊙ DENOTES WELL
- DENOTES EXISTING CONTOURS
- - - DENOTES PROPOSED CONTOURS
- ▨ DENOTES BITUMINOUS SURFACE
- ▩ DENOTES CONCRETE SURFACE
- ▧ DENOTES PAVER SURFACE
- DENOTES PROPOSED ELEVATION.
- DENOTES EXISTING ELEVATION.
- DENOTES DIRECTION OF DRAINAGE.
- ⊙ DENOTES WOOD HUB/METAL SPIKE AT 11 FOOT OFFSET. (UNLESS OTHERWISE NOTED)

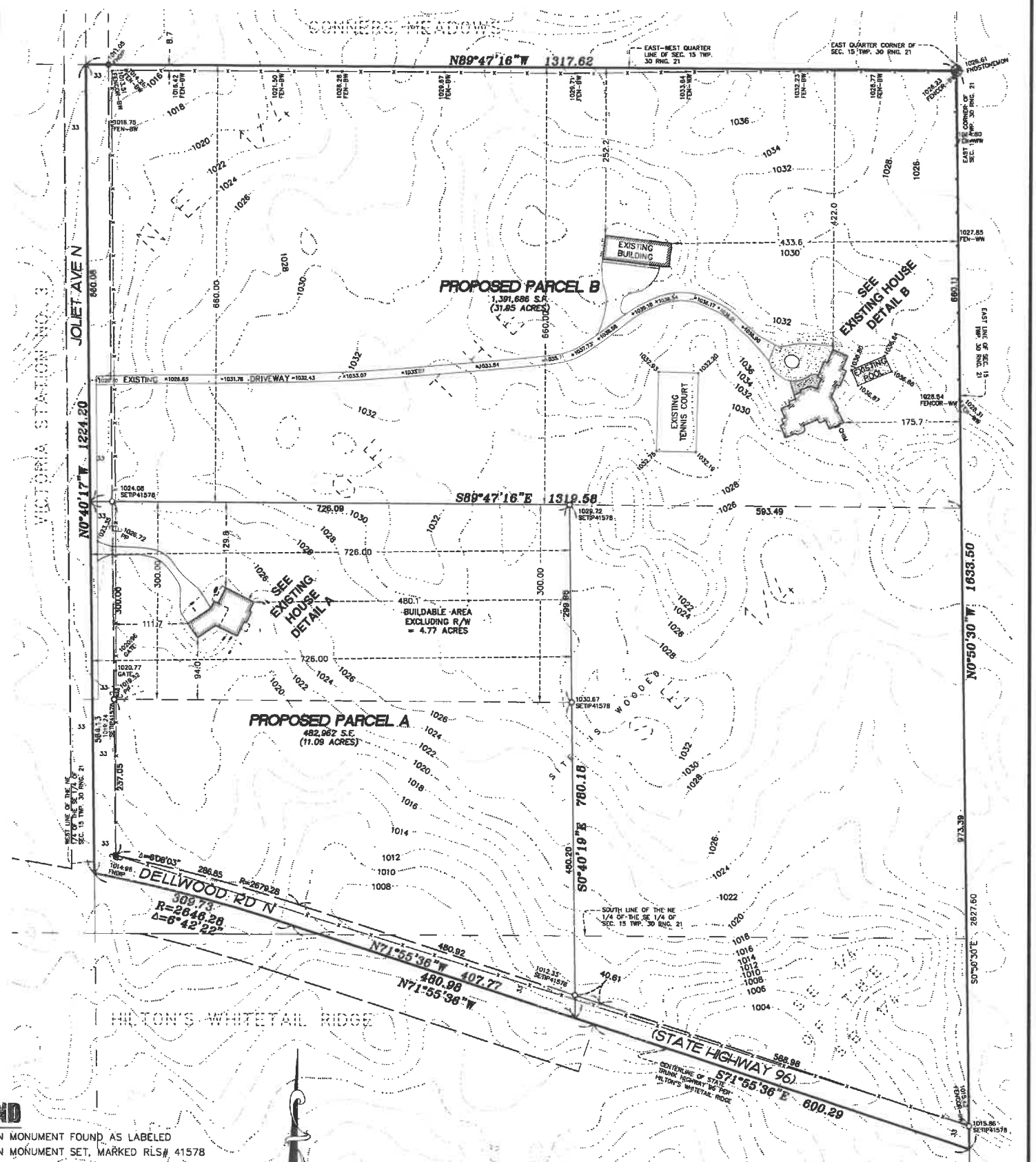

## NORTH

GRAPHIC SCALE



1 INCH = 100 FEET

## BENCHMARK

MNDOT NAME: KENDRICK MNDT AZ MK  
 GSID STATION #: 33596  
 ELEVATION: 936.724 (NAVD88)

I hereby certify that this survey, plan or report was prepared by me or under my direct supervision and that I am a duly Registered Land Surveyor under the laws of the State of Minnesota.

JASON E. RUD  
 Date: 8/11/2020 License No. 41578

NO.	DATE	DESCRIPTION	BY
1	8-03-20	ADD FIELD INFO	CMB
2	8-11-20	CLIENT COMMENTS	CMB
3			

**E.G. RUD & SONS, INC.**  
 Professional Land Surveyors  
 6776 Lake Drive NE, Suite 110  
 Lino Lakes, MN 55014  
 Tel. (651) 361-8200 Fax (651) 361-8701

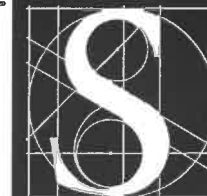

**Sjoquist Architects, Inc**  
 2800 University Avenue SE, Suite 100  
 Minneapolis, Minnesota 55414  
 612.379.0233 Fax 612.379.0263  
<http://www.sjoquist.com>

I hereby certify that this plan, specification, or report was prepared by me or under my direct supervision and that I am a duly Licensed Architect under the laws of the state of

MINNESOTA

Signature \_\_\_\_\_

Architect / Registration \_\_\_\_\_

Date 2020.08.13

Drawn by PMS / Checked by M&T

Revisions \_\_\_\_\_

1952  
 Project Number

AMERICAN  
 POLYWATER  
 CORPORATION

CONDITIONAL  
 USE PERMIT  
 APPLICATION

11222 60TH ST NORTH  
 STILLWATER, MN

1/32" = 1'-0"  
 SITE PLAN -  
 EAST BUILDING

AS101

PARKING				PROPOSED ADDITION				
EXISTING BUILDING				MAIN	MEZZ	TOTAL	AREA/ STALL	STALLS
	AREA / STALL	STALLS						
GROSS AREA	24,030 SF		9,000 SF	3,550 SF	12,550			
OFFICE AREA	3,662 SF	200	3,368 SF	2,222 SF	5,590	200	28	
MFG / WAREHOUSE AREA	20,368 SF	2,000	5,632 SF	928 SF	6,560	2,000	4	
	SPACES REQUIRED	30			SPACES REQUIRED		32	
	SPACES PROVIDED	30			SPACES PROVIDED		32	

**HARD SURFACE**  
 EXIST HARD SURFACE : 50,164.64 SF  
 EXIST BUILDING AREA : 24,000 SF  
 EXIST PAVING/PARKING AREA : 23,888.24 SF  
 EXIST SIDEWALK AREA : 2,716.4 SF

ADDITIONAL HARD SURFACE : 215,384.3 SF  
 ADDITIONAL BUILDING AREA : 9,000 SF  
 ADDITIONAL PAVING/PARKING AREA : 11,615.16 SF  
 ADDITIONAL SIDEWALK AREA : 863.21 SF

TOTAL HARD SURFACE : 171,103.07 SF  
 SITE AREA : 126,249.61 SF  
 RATIO : 56.73%

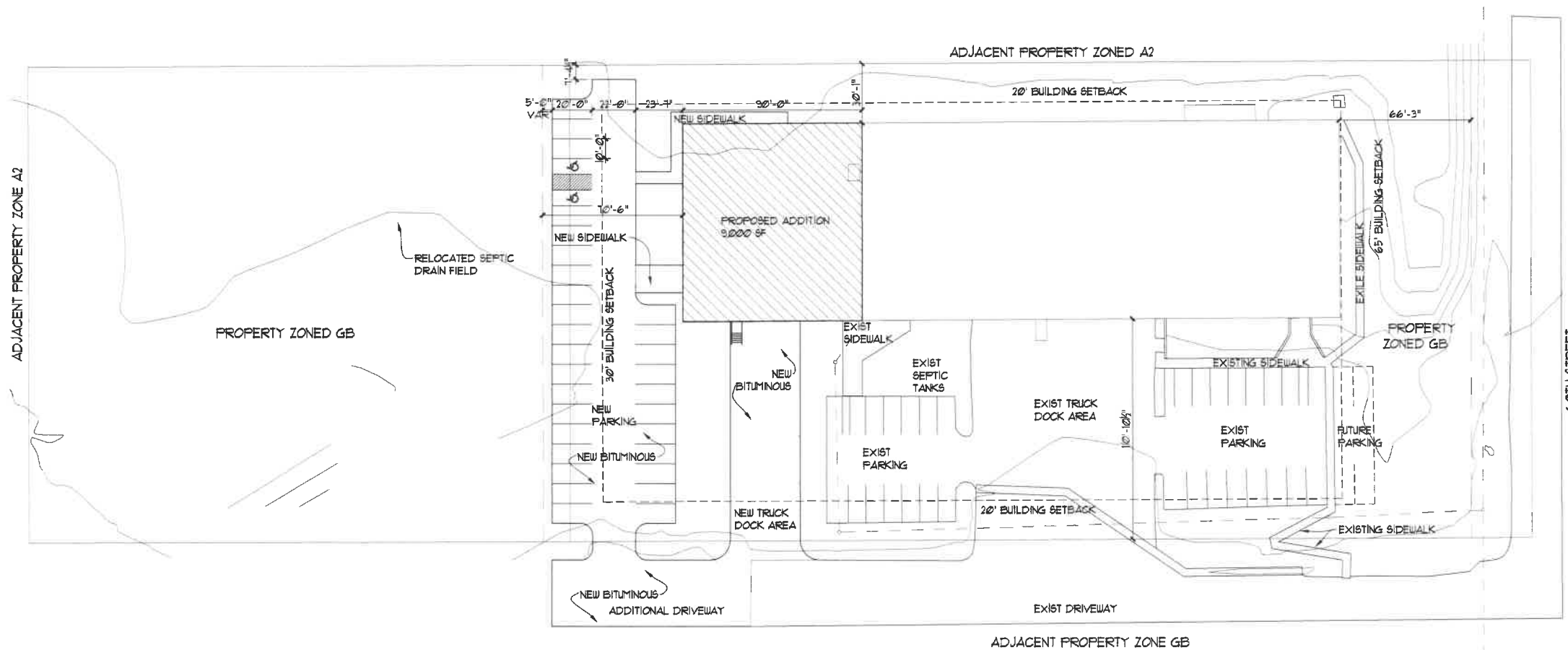

A1 SITE PLAN - EAST BUILDING  
 AS101 1/32" = 1'-0"

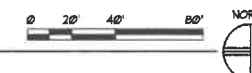

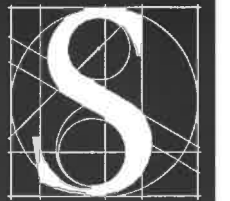

**Sjoquist Architects, Inc**  
 2800 University Avenue NE, Suite 100  
 Minneapolis, Minnesota 55414  
 612.579.9235 Fax 612.579.9263  
<http://www.sjoquist.com>

I hereby certify that this plan, specification, or report was prepared by me or under my direct supervision and that I am a duly Licensed Architect under the laws of the state of

MINNESOTA

Signature \_\_\_\_\_

Architect / Registration \_\_\_\_\_

2020.08.13  
 Date

PMS Drawn MST Checked

Revisions \_\_\_\_\_

1952  
 Project Number

AMERICAN POLYWATER CORPORATION

CONDITIONAL USE PERMIT APPLICATION

11222 60TH ST NORTH  
 STILLWATER, MN

LANDSCAPE PLAN  
 FENCE DETAILS

L-101

PLANT SCHEDULE						
SYMBOL	COMMON NAME	BOTANICAL NAME	QUANTITY	SIZE	METHOD	REMARK
(A)	CHINESE SILVER GRASS	MISCANTHUS SINENSIS	29	#3	CONTAINER	1
(B)	KARL FOERSTER	CALAMAGROSTIS ACUTIFOLIA	82	#3	CONTAINER	2
(C)	AUTUMN BLAZE MAPLE	ACER X FREDMANII 'JEFFERRED'	4	4" MIN	BALL & BURLAP	3
(D)	SCOTCH PINE	PINUS SYLVESTRIS	11	8"	BALL & BURLAP	4
(E)	RIVER BIRCH (CLUMP)	BETULA NIGRA 'CLUMP'	2	2' MIN	BALL & BURLAP	3
(F)	RED OAK	QUERCUS RUBRA	2	4" MIN	BALL & BURLAP	3

- REMARKS:  
 1 PLANT 4' OC  
 2 PLANT 4' OC  
 3 PLANT 40' OC  
 4 PLANT 20' OC

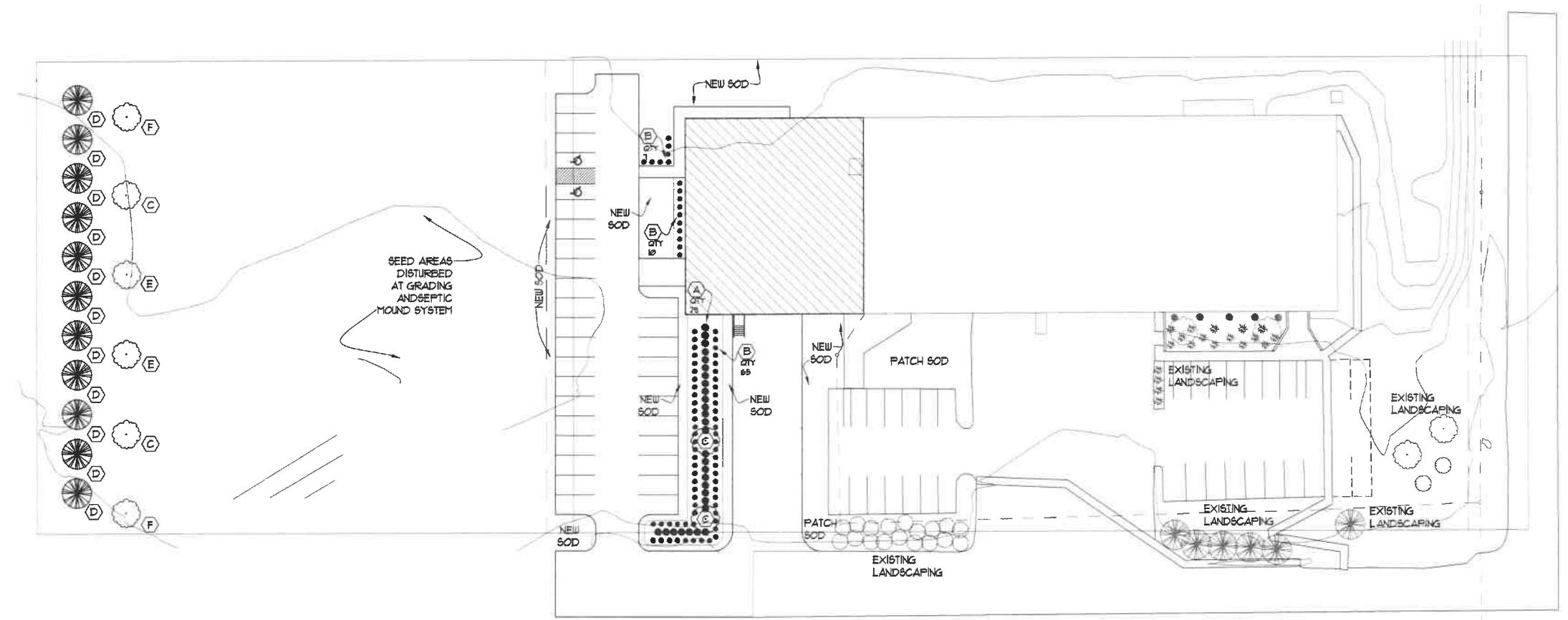

A1 PROPOSED LANDSCAPE PLAN  
 L-101 1/32" = 1'-0"

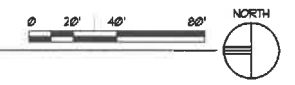

CODE ANALYSIS - 2020 MNBC

TOTAL OCCUPANTS = 112		
OFFICE	• 100 SF/OCC	$\frac{8,113 \text{ SF}}{100 \text{ SF/OCC}} = 81 \text{ OCC}$
MANUFACTURING	• 200 SF/OCC	$\frac{10,521 \text{ SF}}{200 \text{ SF/OCC}} = 53 \text{ OCC}$
WAREHOUSE	• 500 SF/OCC	$\frac{15,252 \text{ SF}}{500 \text{ SF/OCC}} = 31 \text{ OCC}$

SPRINKLERED	YES
MEZZANINE	
GROSS AREA OF PROPOSED ADDITION	5,000 SF
INTERIOR AREA OF PROPOSED ADDITION	8,103 SF
INTERIOR AREA OF PROPOSED ADDITION	2,901 SF
AREA OF PROPOSED MEZZANINE	2,849 SF
MEZZANINE LESS THAN 1/2 OF PROPOSED ADDITION	YES

PLUMBING FIXTURES	REQUIRED / PROVIDED
WATER CLOSETS	
FEMALE	4 / 4
MALE	4 / 3 TOILETS, 3 URINALS
LAVATORIES	
FEMALE	4 / 4
MALE	4 / 4
DRINKING FOUNTAINS	3 / 1 EXIST, 2 ADDITIONAL
SERVICE SINK	1 / 1

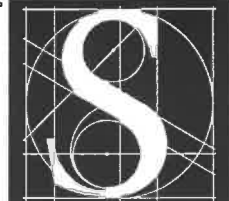

**Sjoquist Architects, Inc**  
 2800 University Avenue SE, Suite 100  
 Minneapolis, Minnesota 55414  
 612.370.9233 Fax 612.370.9263  
<http://www.sjoquist.com>

I hereby certify that this plan, specification, or report was prepared by me or under my direct supervision and that I am a duly Licensed Architect under the laws of the state of

MINNESOTA

Signature \_\_\_\_\_  
 Architect / Registration \_\_\_\_\_  
 2020.08.13  
 Date  
 PMB Draw MST  
 Checked

Revisions

1952  
 Project Number

AMERICAN  
 POLYWATER  
 CORPORATION

CONDITIONAL  
 USE PERMIT  
 APPLICATION

11222 60TH ST NORTH  
 STILLWATER, MN

3/32" = 1'-0"  
 FIRST FLOOR PLAN -  
 EAST BUILDING - OPTION C

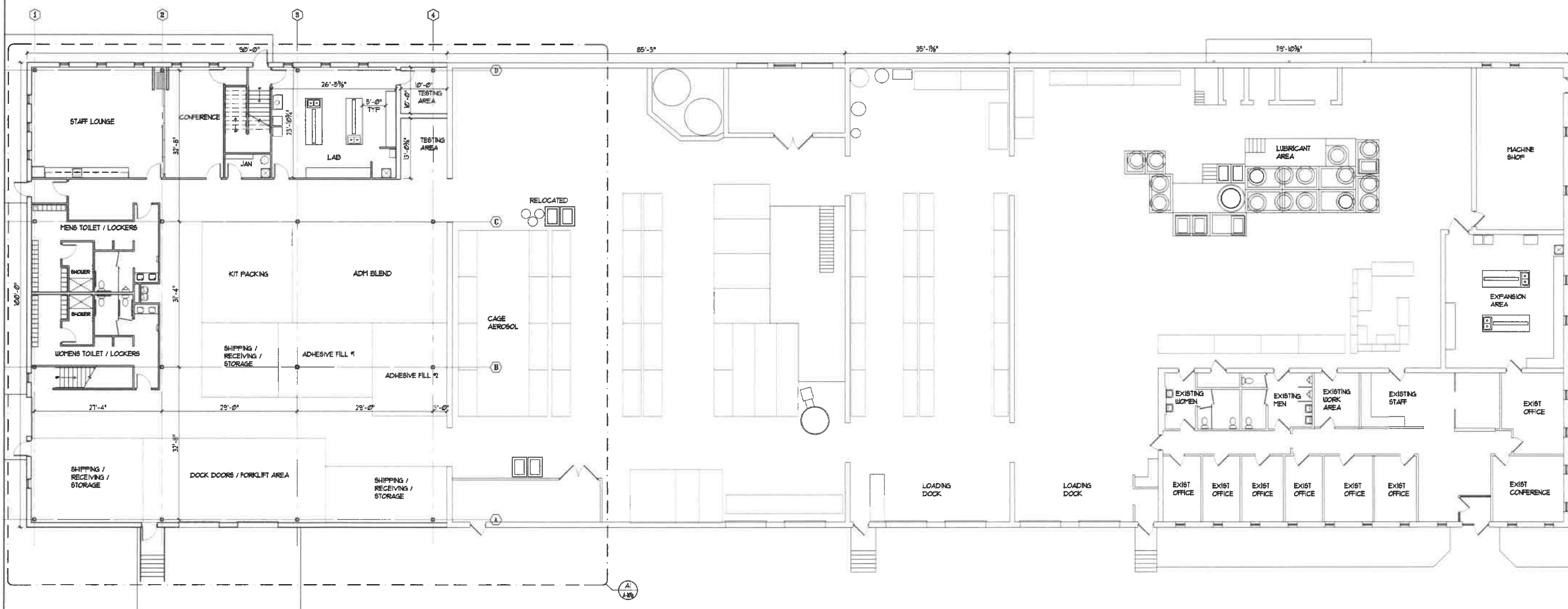

A1 PROPOSED FIRST FLOOR PLAN - EAST BUILDING  
 A-101 3/32" = 1'-0"

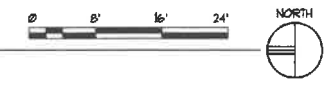

A-101

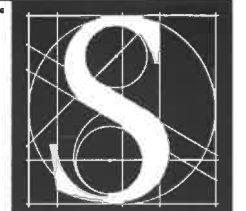

**Sjoquist Architects, Inc**  
 2800 University Avenue SE, Suite 100  
 Minneapolis, Minnesota 55414  
 612.379.9235 Fax: 612.379.9263  
<http://www.sjoquist.com>

I hereby certify that this plan, specification, or report was prepared by me or under my direct supervision and that I am a duly Licensed Architect under the laws of the state of

**MINNESOTA**

Signature \_\_\_\_\_

Architect / Registration \_\_\_\_\_

2020.08.13  
 Date

PM6 Draw MST  
 Drawn Checked

Revisions \_\_\_\_\_

1952  
 Project Number

**AMERICAN POLYWATER CORPORATION**

CONDITIONAL  
 USE PERMIT  
 APPLICATION

11222 60TH ST NORTH  
 STILLWATER, MN

3/16" = 1'-0"  
 FIRST FLOOR PLAN ADDITION -  
 EAST BUILDING - OPTION C

**A-101a**

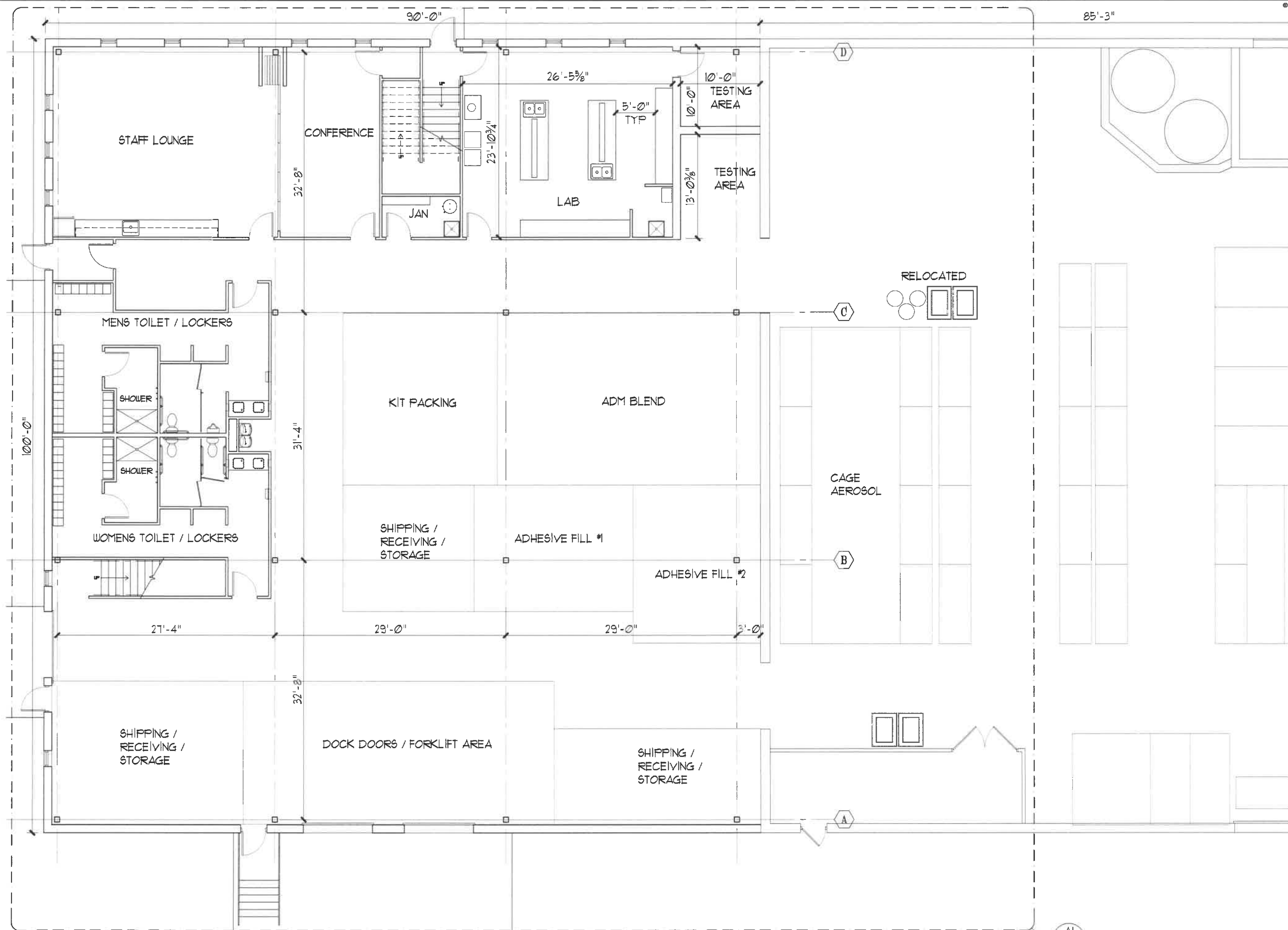

**A1** PROPOSED FIRST FLOOR PLAN ADDITION - EAST BUILDING  
 A-101a 3/16" = 1'-0"

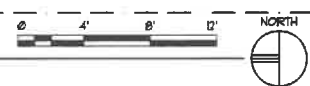

**A1**  
 A-102a MEZZANINE

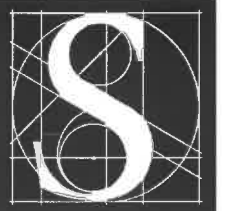
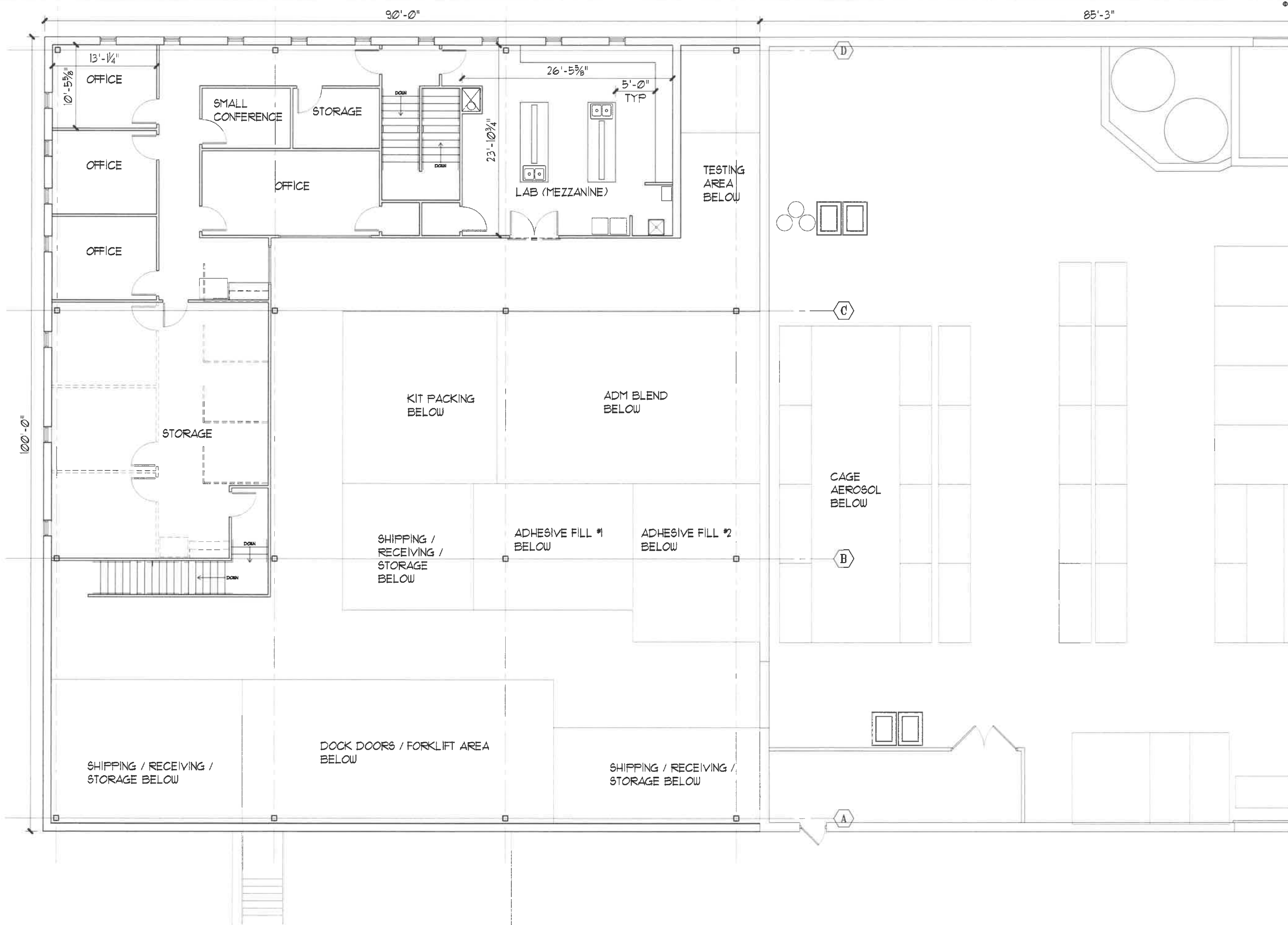

**Sjoquist Architects, Inc**  
 2800 University Avenue SE, Suite 100  
 Minneapolis, Minnesota 55414  
 612.379.9233 Fax: 612.379.9263  
<http://www.sjoquist.com>

I hereby certify that this plan, specification, or report was prepared by me or under my direct supervision and that I am a duly Licensed Architect under the laws of the state of

**MINNESOTA**

Signature \_\_\_\_\_

Architect / Registration \_\_\_\_\_

2020.08.13  
 Date

PM16 Drawn MST  
 Checked

Revisions \_\_\_\_\_

1952  
 Project Number

**AMERICAN  
 POLYWATER  
 CORPORATION**

**CONDITIONAL  
 USE PERMIT  
 APPLICATION**

11222 60TH ST NORTH  
 STILLWATER, MN

3/16" = 1'-0"  
 MEZZANINE FLOOR PLAN -  
 EAST BUILDING - OPTION C

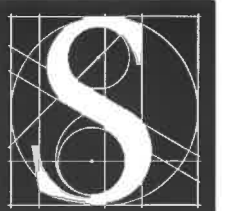

**Sjoquist Architects, Inc**  
2800 University Avenue SE, Suite 100  
Minneapolis, Minnesota 55414  
612.379.9233 Fax: 612.379.9263  
<http://www.sjoquist.com>

I hereby certify that this plan, specification, or report was prepared by me or under my direct supervision and that I am a duly Licensed Architect under the laws of the state of

MINNESOTA

Signature \_\_\_\_\_

Architect / Registration \_\_\_\_\_

2020.08.13  
Date

PMG Drawn MGT Checked

Revisions \_\_\_\_\_

1952  
Project Number

AMERICAN  
POLYWATER  
CORPORATION

CONDITIONAL  
USE PERMIT  
APPLICATION

11222 60TH ST NORTH  
STILLWATER, MN

3/32" = 1'-0"

EXTERIOR ELEVATIONS  
EAST BUILDING

A-201

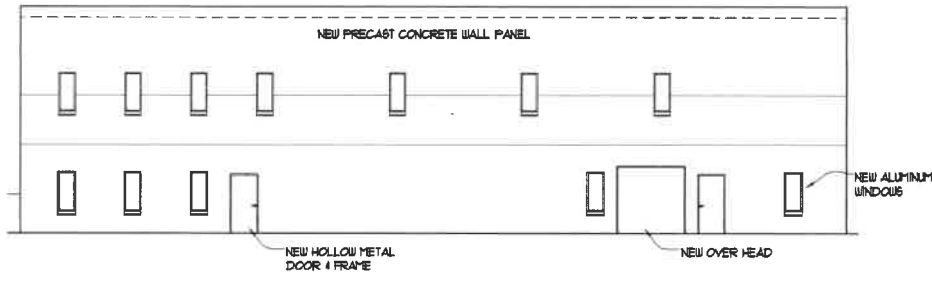

D1  
A-20  
EXTERIOR ELEVATION - NORTH  
3/32" = 1'-0"

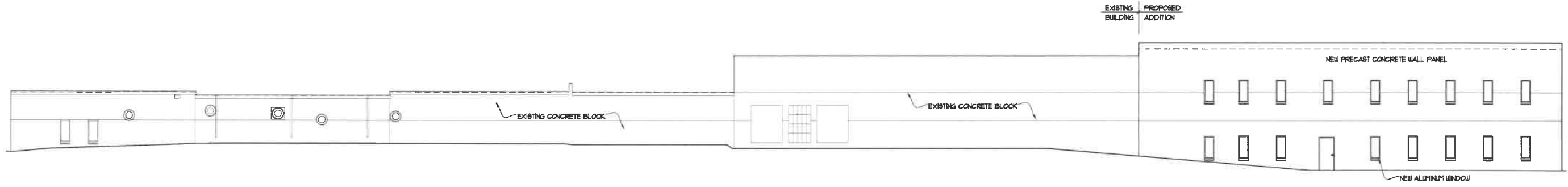

C1  
A-20  
EXTERIOR ELEVATION - EAST  
3/32" = 1'-0"

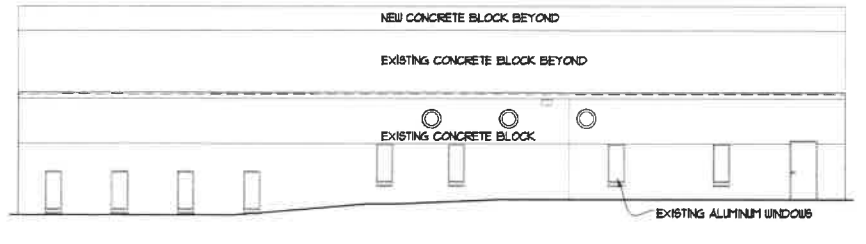

B1  
A-20  
EXTERIOR ELEVATION - SOUTH  
3/32" = 1'-0"

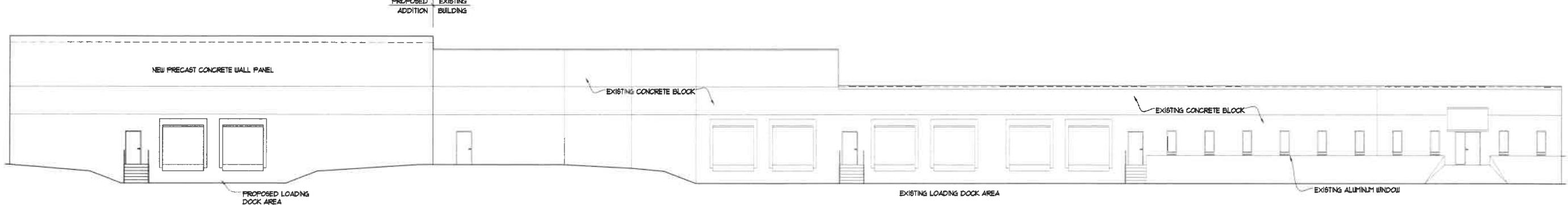

A1  
A-20  
EXTERIOR ELEVATION - WEST  
3/32" = 1'-0"



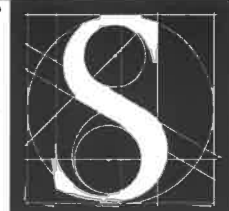

Sjoquist Architects, Inc  
2800 University Avenue SE, Suite 100  
Minneapolis, Minnesota 55414  
612.379.9233 Fax 612.379.9263  
http: www.sjoquist.com

SCHULTZ ENGINEERING & SITE DESIGN  
18 South Riverside Avenue  
Suite 230  
Scarlet, MN 56377  
Ph: (320) 339-0669  
Fax: (866) 633-7830  
schultzeng@live.com  
www.schultzengineeringdesign.com

I hereby certify that this plan, specification or report was prepared by me or under my direct supervision and that I am a duly licensed Engineer under the laws of the state of Minnesota

BRIAN J. SCHULTZ, PE  
XX/XX/2020 43129  
DATE LICENSE NO.  
Revisions

1952  
Sjoquist Project Number  
20004  
Schultz Eng. Project Number

NEW BUILDING  
ADDITION  
AMERICAN  
POLYWATER  
CORPORATION

11222 60TH STREET NORTH  
STILLWATER,  
MINNESOTA

STANDARD NOTES  
& SPECIFICATIONS

C-100.1

PRELIMINARY - NOT FOR CONSTRUCTION VBWD SUBMITTAL - 06/25/2020

**CONCRETE PAVEMENT, CURB & GUTTER, AND SIDEWALK**

**STANDARDS**

- 1) ACI 318, ACI 315, CRSI, ACI 301, latest editions.
  - 2) Minnesota Standard Specifications for Construction, most recent edition.
- GRANULAR BASE COURSE MATERIAL**
- 1) Compacted thickness of finished base: 6" - Concrete Pavement/Aprons  
4" - Concrete Sidewalk.
  - 2) Base material shall consist of MNDOT 31 49,282 Select Granular Borrow.

**AGGREGATES**

- 1) Coarse: MNDOT Spec. 31.37.
- 2) Fine: MNDOT Spec. 31.26.

**WATER**

- 1) Clean, fresh and potable. MNDOT Spec. 39.06.

**AIR ENTRAINING ADMIXTURES**

- 1) ASTM C242.
- 2) Provide entrainment of 4 - 7 percent by volume.

**PORTLAND CEMENT**

- 1) ASTM C150, Type I plus an approved air entraining agent, or Type IA air-entraining Portland cement.

**OTHER ADMIXTURES**

- 1) MNDOT Spec. 31.13.
- 2) Calcium Chloride or materials containing chlorides or nitrates shall not be allowed.

**PROPORTIONING AND DESIGN OF MIXES**

- 1) Concrete Classifications
  - a) Curb and gutter, slip-formed concrete: MNDOT Spec. 2461, Mix Design 3F32
  - b) Sidewalk, aprons, incidental concrete, manual curb & gutter: MNDOT Spec. 2461, Mix Design 3F52
  - c) Concrete pavements: MNDOT Spec. 2301, Mix Design 3A41
  - d) Repair concrete, fast strength concrete: MNDOT Spec. 2301, Mix Design 3A41 HE
- 2) Concrete Specifications:
  - a) 3F32: 2 - 3' slump, 4500 psi, 5-8% air
  - b) 3F52: 2 - 5' slump, 4500 psi, 5-8% air
  - c) 3A41: 2 - 3' slump, 4500 psi, 5-8% air
  - d) Temperatures of all concrete during placement shall be 50-deg F to 90-deg F

**CONCRETE PLACEMENT**

- 1) Place concrete as soon as possible after mixing. Place before initial set has occurred, and in no event after it has contained its water content for more than one hour.
  - 2) Avoid overworking concrete or drawing concrete to full unrestricted for excessive vertical distances, and other situations which can cause segregation of the aggregate.
  - 3) Concrete pavements shall be placed in accordance with applicable portions of MNDOT 2301.
  - 4) Sidewalks shall be placed in accordance with MNDOT 2521.
  - 5) Curb and gutter shall be placed in accordance with MNDOT 2531.
- PROTECTION**
- 1) Provide adequate protection against rain, sleet and snow before and during placement and finishing of concrete.
  - 2) Protect concrete from premature drying. Provide temporary covering as required. Keep concrete continuously moist for 7 days.
  - 3) Treat concrete with membrane curing compounds in accordance with MNDOT 2531.3G.

**COLD WEATHER CONCRETE**

- 1) Do not place concrete when the atmospheric temperature is below 40 degrees F, or when the concrete is likely to be subjected to freezing temperatures within 24 hours after it has been deposited unless adequate temporary heating is provided.
- 2) Maintain concrete temperature of 40 to 90 degrees F, for 3 days. Protect from freezing for the following 5 days.
- 3) No frozen materials may be used in the concrete. Chemicals may not be used to prevent freezing unless approved by the Engineer.
- 4) Perform all cold weather concreting in accord with ACI 306.

**HOT WEATHER CONCRETE**

- 1) Do not place concrete when the atmospheric temperature is above 100 degrees F.
- 2) Maintain concrete temperature of 40 to 90 degrees F, for 3 days. Protect from temperatures over 90 degrees for the following 5 days.
- 3) Thoroughly wet dry porous surfaces before concreting.
- 4) Water-reducing admixtures with retarding properties are required for all concrete placed when the temperature exceeds 80 degrees F.
- 5) Perform all hot weather concreting in accord with ACI 305.

**FINISHING**

- 1) Provide a broomed finish on exterior sidewalks and ramps unless noted otherwise.

**QUALITY CONTROL**

- 1) The Contractor shall hire an independent testing firm to provide the following tests:
  - a) The independent testing technician shall perform random field testing of the fresh concrete including slump, air content, and temperature. (ASTM C143, C173, C251 and C138). One series of the aforementioned tests shall be performed on the first load of concrete.
  - b) The independent testing technician shall cast a set of four compression test cylinders for the first load of concrete as well as a set for every 100 cubic yards, or fraction thereof, of concrete thereafter. Compression tests shall be performed on one test cylinder at 7 days and two test cylinders at 28 days. The fourth test cylinder shall be retained in the event of failing compression tests on the 28-day test cylinders.

**CIVIL SHEET INDEX**

C-100.1	STANDARD NOTES & SPECIFICATIONS
C-100.2	STANDARD DETAILS
C-101.1	GRADING PLAN
C-101.2	SWPPP - PLAN VIEW
C-101.3	SWPPP - PLAN VIEW
C-102	PAVING PLAN

**RETURNING PAYMENT NOTES**

**STANDARDS**

- 1) Minnesota Standard Specifications for Highway Construction, most recent edition.

**GRANULAR BASE COURSE**

- 1) Compacted thickness of finished base course: 8"
- 2) Process material for aggregate base shall meet the requirements of MNDOT Spec. 31.38, Class 5.
- 3) The subgrade shall be tested and observed to the satisfaction of the Engineer prior to placement of aggregate base material. Install base material as required to accommodate new plan grades.
- 4) Wet base material to approximate optimum moisture content either prior to delivery to job site or as soon as practical after being placed on subgrade.
- 5) Place in layers not exceeding 4" thickness (loose).
- 6) Compact with pneumatic or vibrating steel drum rollers.
- 7) After base course has been graded and compacted, thoroughly wet and slash roll with roller until all aggregates are thoroughly embedded.
- 8) Allow base course to cure for a minimum of 72 hours prior to bituminous course application.

**BITUMINOUS BASE AND SURFACE COURSE**

- 1) Mix Designation Numbers for the bituminous mixtures on this project are per MNDOT Spec. 2360.
- 2) Pavement smoothness requirements will be waived for this project.
- 3) Density for the bituminous mixture on this project will be the ordinary compaction method (MNDOT 2360.6C).
- 4) Heavy Duty Pavement: Bituminous Base course shall conform to MNDOT 2360, Type SPNWB3308 and shall be 2 inches thick after compaction. Bituminous Surface course shall conform to MNDOT 2360, Type SPWEA3408 and shall be 2 inches thick after compaction.
- 5) Light-Duty Pavement: Bituminous Base course shall conform to MNDOT 2360, Type SPNWB3308 and shall be 1- inches thick after compaction. Bituminous Surface course shall conform to MNDOT 2360, Type SPWEA3408 and shall be 1- inches thick after compaction.
- 6) Place an asphaltic mixture when the atmospheric temperature is below 45 degrees and falling, nor should pavement be placed under wet conditions.
- 7) Mixing
  - a) Paving mixture: Uniform mixture of coarse aggregate, fine aggregate, mineral filler and asphaltic material.
  - b) Grading and mixing: Conform to applicable sections of the Minnesota Standard Specifications for Highway Construction, Section 2360.

**CONSTRUCTION METHODS**

- 1) Properly clean base course and deliver hot mix asphaltic concrete in clean light vehicles with covers if necessary.
- 2) Lay to a smooth surface without segregation of material and attain compaction as early as possible. Commence rolling while the material is hot. (minimum spread temperature 250 degrees F) as soon as it will support the roller without undue displacement or hoarse cracking and continue until a minimum of 98% of maximum has been attained, no further compaction can be obtained and all roller marks are eliminated.
- 3) The completed surface: Smooth, free of pockets that will retain water and shall not vary more than 1/16" per foot nor more than 1/4" under a 16' straight edge. Entire surface must drain. No flat areas are permitted.
- 4) Perform all Work in accordance with the applicable requirements of the Minnesota Standard Specifications for Highway Construction.

**PAINTED LINES**

- 1) Special marking paint compound especially for striping bituminous paving in one coat.
- 2) Manufacturer: Pratt & Lambert, Inc.; Sherwin Williams Co. or DuPont Co.
- 3) Colors: Use white paint for concrete and asphalt.
- 4) All surfaces to be painted must be thoroughly clean and dry.
- 5) Lay out painted lines with chalk on pavement in accordance with Project Drawings.
- 6) Accurately apply paint to the chalk marks, using striping machines, 4" wide stripes.
- 7) Apply paint in strict accordance with the manufacturer's directions.
- 8) Protect all paint from damage by traffic until dry.
- 9) Apply handcap legs at handcap stall.

**FIELD QUALITY CONTROL**

- 1) Aggregate Base Testing:
  - a) The granular base course shall be test rolled and observed by the Contractor's independent soils technician as per MNDOT 2211.3C2 (Quality Compaction Method). Once the base course has been tested to the satisfaction of the Engineer, pavement may be placed.
  - b) One mechanical analysis (ASTM D-422) per 500 cubic yards of base or fraction thereof.
- 2) Bituminous Testing:
  - a) Test temperature of first truck.
  - b) Ordinary compaction (MNDOT 2360.6C)

Optimum moisture-density relationship will be determined by testing laboratory in accordance with ASTM D498 and maximum density determination made by Method D of ASTM D498 unless otherwise noted in these specifications.

**SUBGRADE PREPARATION**

- 1) Finished subgrade elevations shall be as follows:
  - a) Heavy-duty bituminous pavement: 12" below finish grade.
  - b) Light-duty bituminous pavement: 11" below finish grade.
  - c) Concrete pavement/apron: 12" below finish grade.
  - d) Concrete sidewalk: 8" below finish grade.
  - e) Lawn areas: 4" below finish grade.
- f) Planting areas: See Landscaping Plans/Details
- 2) The tolerance for areas to be paved shall not exceed 0.15 feet above or below plan subgrade.
- 3) The Contractor shall protect newly graded areas from erosion. Settlement or washing that occurs prior to acceptance of the Work shall be repaired and grades re-established.

**DISPOSAL OF EXCESS WASTE MATERIALS**

- 1) The Contractor shall remove excess excavated material, debris, and waste materials, from the Owner's property and legally dispose of it in accordance with all governing codes.

**SPREADING TOPSOIL AND FINISH GRADING**

- 1) Scarify subgrade to depth of 3" prior to placing topsoil. Spread topsoil evenly over complete subgrade as follows:
  - a) Lawn Areas on Private Property: Spread 4" lightly compacted layer of topsoil.
  - b) Lawn Areas in Public Right-of-way: Per City requirements
  - c) Planting Areas: See Landscaping Plan/Details
- 2) Finish grade accurately within 0.15 feet of finish grades shown on the project drawings, less the thickness of any sod where it is to be installed. Slope all grades away from buildings to provide positive drainage.
- 3) Prepare topsoil suitable to receive seed and/or sod. Grading of areas designated for topsoil shall be reasonably smooth and even, and in accordance with MNDOT Spec. 2105.3G and 2574.3A4. All debris and stones exceeding 3" in diameter shall be removed from the soil surface of these areas prior to seeding. Areas compacted by vehicles or storage of materials shall be plowed, disked and harrowed to match texture of other finish graded areas.
- 4) Grass seed shall be in accordance with MNDOT Spec. 3876, seed mix No. 26-131, applied at the rate of 220 pounds per acre or as indicated on the landscape plans. Mulch shall be applied and dischurned to all seeded areas and shall meet the requirements of MNDOT Spec. 3882, type 3 or as otherwise indicated by the Engineer.

**UTILITY NOTES**

**STANDARD SPECIFICATIONS**

- 1) The following standard specifications shall apply to this project:
  - a) Minnesota Plumbing Code - MN Rules Chapter 4714 (MN Dept. of Labor and Industry-MNDL)
  - b) Uniform Plumbing Code, latest edition (UPC)
  - c) "What you need to know about utility service connections in the 2015 Minnesota Plumbing Code" <http://www.dhs.mn.gov/CDD/UPC/PDF/Use.pdf>
  - d) City Engineers Association of Minnesota (CEAM) Standard Specifications
  - e) American Society for Testing Materials (ASTM)
  - f) American National Standards Institute (ANSI)
  - g) American Water Works Association (AWWA)
  - h) Minnesota Department of Transportation "Standard Specifications for Construction" (MNDOT)
- 2) The Contractor shall comply with all local ordinances and codes.
- 3) Certifications of all utility materials, as well as shop drawings, shall be submitted to the Engineer for review.

**HIGH DENSITY POLYETHYLENE PIPE (HDPE) AND FITTINGS - STORM**

- 1) HDPE pipe and fittings shall meet the requirements of ASTM F2306, and Section 2621.2A6 of the CEAM Standard Specifications
- 2) Pipe joints shall meet the requirements Section 2621.3A3 of the CEAM Standard Specifications
- 3) Minimum wall thickness shall be 0.035 inches for 12 and 15 inch diameter pipe and shall be 0.05 inches for 18 and 24 inch diameter pipe

**POLYVINYL CHLORIDE (PVC) PIPE AND FITTINGS - STORM**

- 1) PVC storm sewer pipe and fittings within 10-ft of a building and/or water pipe crossing, or when specified on the plans, shall consist of Schedule 40 PVC, and meet the requirements of ASTM D1785 ASTM D2665, and ASTM F74, and Section 2621.2A5 of the CEAM Standard Specifications
- 2) If further than 10-ft from a building and/or water pipe crossing, PVC storm sewer pipe and fittings may consist of SDR 26 or SDR 35 pipe, unless noted otherwise, and meet the requirements of ASTM D3334 and Section 2621.2A5 of the CEAM Standard Specifications
- 3) All pipe and fittings shall be SDR 35 for depths of up to 20 feet, and SDR 26 for depths exceeding 20'.
- 4) Pipe joints shall meet the requirements of Section 2621.3A3 of the CEAM Standard Specifications.

**REINFORCED CONCRETE SEWER PIPE (RCP) AND FITTINGS - STORM**

- 1) RCP pipe and fittings shall meet the requirements of ASTM C76, and Section 2621.2A3 of the CEAM Standard Specifications
- 2) Pipe joints shall meet the requirements of Section 2621.3A3 of the CEAM Standard Specifications
- 3) The ASTM strength class of pipe shall be Class III unless otherwise shown on the Plans.
- 4) The pipe shall be drawn together by some approved method of jacking or winching. This pressure must be maintained until sufficient backfill is placed to keep the joint from opening.

**END SECTIONS - STORM**

- 1) End sections shall be provided at all pipe inlets and outlets.
- 2) The end sections shall consist of material matching the material of the pipe, which it is being connected to. Materials and joints shall be as per the specifications described above for the applicable pipe material.
- 3) The last 3 joints of RCP shall be tied, and the end section shall be provided with an approved trash guard.

**MANHOLES AND CATCH BASINS - STORM**

- 1) Unless otherwise noted, manhole and catch basin structures shall consist of precast concrete, and meet the requirements of Sections 2621.2C and 2621.3D of the CEAM Standard Specifications
- 2) Catch basins shall be provided with the following coatings:
  - a) Along cutline: 27" Structure: Neenah R-3075-L, 48" (or larger) Structure: Neenah R-3067-L
  - b) Isolated (in paved area): Neenah R-2553
  - c) Isolated (in vegetated area): Neenah R-2560-EA w/ type "C" grate
- 3) Manholes shall be provided with the following coatings:
  - a) Storm: Neenah R-1733 lettered "STORM", center pick hole

**INSTALLATION**

- 1) Unless otherwise noted, installation of all water and sewer pipe, fittings, and appurtenances shall be as per the CEAM Standard Specifications.

**TESTING REQUIREMENTS**

- 1) Water and sewer pipe, fittings, and appurtenances shall be inspected and tested as per Sections 2611.3E, 2611.3H and 2621.3F-2621.3H of the CEAM Standard Specifications.
- 2) In the event of discrepancies between the testing requirements of the MN Plumbing Code and the CEAM Standard Specifications, the most stringent will govern.

**STANDARDS AND REFERENCES**

Materials and construction methods specified in the plans reference the Minnesota Department of Transportation (MNDOT) Standard Specifications for Construction. The Contractor shall obtain a current copy of MNDOT Standard Specifications for Construction and review the specification sections applicable to the plans.

It is mandatory that the Contractor be knowledgeable of the applicable MNDOT specification sections during construction. No additional compensation will be paid to the Contractor for additional work due to unfamiliarity with the applicable specification sections.

Contractor shall refer to the geotechnical report for additional requirements and recommendations.

**EARTHWORK NOTES**

**PROTECTION**

- 1) The Contractor shall maintain all benchmarks, monuments and other reference points. If any are disturbed or destroyed, they shall be replaced at the Contractor's expense.
- 2) The Contractor shall contact the Engineer immediately if any unknown functioning underground utilities are discovered during the course of the project, which may interfere with construction. The Contractor shall wait for instructions before proceeding.
- 3) The Contractor shall be responsible for any damage to functioning underground or overhead utility lines. Damaged utilities shall be repaired immediately and service restored at no additional cost to the Owner.
- 4) The Contractor shall provide barricades, staking and other safety measures required by OSHA.
- 5) The Contractor shall protect all adjacent existing facilities from damage, including, but not limited to settlement due to excavations, erosion, etc. The Contractor shall be responsible for the repair of such damages.

**PROJECT CONDITIONS**

- 1) The Contractor shall become familiar with the project site, and compare actual conditions in the field with those shown on the project drawings. The Contractor shall contact the Engineer immediately if any inconsistencies are found between the existing conditions and the project drawings.
- 2) No extra compensation will be allowed due to unusual conditions which could have reasonably been determined or anticipated by examination of the project site and project drawings.

**PLAN GRADES**

- 1) Elevations shown on the project drawings are finished grade elevations, unless noted otherwise. Elevations not specifically indicated shall be determined by interpolation of uniform slope between spot elevations and/or contours, or between such points and existing elevations. Adequate slope shall be constructed to provide positive drainage away from structures.
- 2) If inconsistencies exist on the plans between contours and spot elevations, the spot elevations shall govern.

**TOPSOIL**

- 1) Adequate imported and/or stockpiled salvagable topsoil shall be utilized for this project.
- 2) Topsoil shall be free of clay lumps, roots, brush, large stones, and debris, and shall have a minimum organic content of 5 percent.
- 3) Remove topsoil to its entire depth from areas, which are to be disturbed by new construction work. Existing topsoil shall be determined by interpolation of uniform slope between spot elevations and/or contours, and verify topsoil depths between any soil borings, and remove to greater depths than indicated in the soils report if such conditions are encountered. Salvaged topsoil shall be maintained in stockpiles.
- 4) Stockpiled topsoil shall only be used for finish grading of new lawn areas. Excess topsoil shall be removed from the site by the Contractor.
- 5) Protect all existing lawn areas, plantings, and other landscaping to remain in place. Any damaged areas shall be replaced at the Contractor's expense.

**UNFORESEEN OBSTACLES**

- 1) The Engineer shall be contacted immediately if any unforeseen major obstacles are encountered during excavation, such as abandoned wells, abandoned or functioning utilities, subsurface streams or rock, etc., which would add significant expense to the Contractor.
- 2) The Contractor shall still be responsible for completing all work required for this project where encountered conditions may be reasonably determined from a geotechnical report and review of the project site and contract documents.

**DEWATERING**

- 1) Surface drainage shall be provided during construction in a manner so as not to create a nuisance to adjacent areas.
- 2) All excavations shall be free of water during construction within the excavation. Dewatering shall be accomplished by pumping or trenching, and shall be conducted regardless of the cause, source, or nature of the water.
- 3) Berms, cofferdams, or piling shall be provided as necessary to protect excavations.
- 4) Excavations shall be sloped to drain, and necessary pumps, hoses and other equipment shall be provided to keep excavation free of water.
- 5) All temporary equipment used for dewatering shall be removed from the site when no longer necessary.

**FILLING AND GRADING**

- 1) Rough grading of all areas within the construction limits, including adjacent transition areas shall be reasonably smooth and compacted. The rough graded subgrade surface generally shall not be more than 6 inches above or below the established subgrade elevations. All ditches, swales, and gutters shall be graded to drain adequately. The subgrade shall be evenly sloped to provide drainage away from building walls in all directions of a minimum slope of 1%. The Contractor shall provide rounded transitions at top and bottom of banks and other breaks in grade.
- 2) Fill and backfill materials shall be inorganic soils free of roots, rocks, boulders, and debris.
- 3) Backfill material or granular backfill larger than 2" in its largest dimension shall not be allowed within 2 feet of new underground pipes. Material larger than 3" in its largest dimension shall not be allowed within 1 foot of subgrade elevation.
- 4) Imported compacted fill material shall have a maximum of 12 percent passing the #200 sieve, by weight. The proposed fill material shall be tested by an independent testing lab for suitability as compacted fill for the project. The Contractor shall pay for the testing services and provide a copy of the test results to the Engineer.
- 5) The Contractor shall fill and grade as necessary to bring surface to required elevations, and provide all materials necessary, whether obtained on or off the project site.
- 6) The Contractor shall place compacted material in uniform horizontal lifts not exceeding 8" in depth for clay soils, and 12" in depth for sandy soils, and compact as required to achieve specified density.
- 7) Compaction shall be obtained with the use of vibratory rollers or rammers. During compaction, fill material shall contain moisture content, as necessary, for the required compaction as indicated by an independent testing laboratory. The moisture shall be uniform throughout each lift. If the material is too dry, water shall be added with approved equipment and methods, which will not wash out fine materials. If the material is too wet, it shall be airted by harrowing, disk, blade, or other approved methods recommended by the independent testing laboratory.
- 8) Areas designated for pavement in excavated (cut) areas shall be scarified to a depth of 1 foot. The Contractor shall bring the subgrade material to optimum moisture content as indicated by the independent testing laboratory, and compact the subgrade to the specified density listed below for soils underneath pavements.
- 9) The Contractor shall not place fill material when either the fill material, or the material on which it is to be placed, is frozen. Any soft or yielding areas appearing in the fill resulting from frost, rain, or any other reason whatsoever shall be scarified, removed, recompacted and/or otherwise rectified to the satisfaction of the Engineer before any new fill is placed.

**COMPACTION TESTS**

- 1) Utility Trench Backfill: The Contractor's independent soils technician and approved testing laboratory shall perform in-place density and moisture tests at random depths in trench backfill at 100 foot intervals, or fraction thereof. Compaction of trenches shall be a minimum of 95% of the maximum dry density (as determined by the independent testing laboratory) in lawn areas, and at depths greater than 3 feet below areas designated for pavement. Compaction of trenches at depths within 3 feet of paved surfaces shall be a minimum of 100% of the maximum dry density.
- 2) Compacted Fill Under Pavements: Compaction tests shall not be required beneath new pavements. Adequate compaction of materials under pavements shall be determined by test using the subgrade, and checking for excessive rutting. Test rolling shall be performed as per MNDOT Spec. 2111.
- 3) Areas exhibiting a failed compaction test shall be re-compacted and re-m tested to the satisfaction of the Engineer prior to acceptance of the project.
- 4) Copies of all compaction testing and test roll observation reports shall be provided to the Engineer.



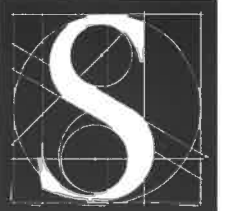

Sjoquist Architects, Inc  
2800 University Avenue SE, Suite 100  
Shawapohs, Minnesota 55414  
612.379.9253 Fax 612.379.9265  
http://www.sjoquist.com

SCHULTZ ENGINEERING & SITE DESIGN  
18 South Riverside Avenue  
Suite 230  
Scarlet, MN 56377  
Ph: (320) 339-0669  
Fax: (866) 633-1830  
schultzeng@live.com  
www.schultzengineeringdesign.com

I hereby certify that this plan, specification or report was prepared by me or under my direct supervision and that I am a duly licensed Engineer under the laws of the state of Minnesota

BRIAN J. SCHULTZ, PE  
XX/XX/2020 DATE 43129 LICENSE NO.  
Revisions

1952 Sjoquist Project Number  
20004 Schultz Eng. Project Number

NEW BUILDING ADDITION  
AMERICAN POLYWATER CORPORATION

11222 60TH STREET NORTH  
STILLWATER, MINNESOTA

STANDARD DETAILS

C-100.2

PRELIMINARY - NOT FOR CONSTRUCTION  
VBWD SUBMITTAL - 06/25/2020

**CASTINGS**  
MANHOLES:  
NEENAH R-1733-1 (LETTERED "STORM") W/ CONCEALED PICKHOLE  
CATCH BASINS:  
NEENAH R-3067-L (IN C&G)  
NEENAH R-2553 (ISOLATED)  
NEENAH R-2560-EA (ISOLATED BEEHIVE) - TYPE C GRATES

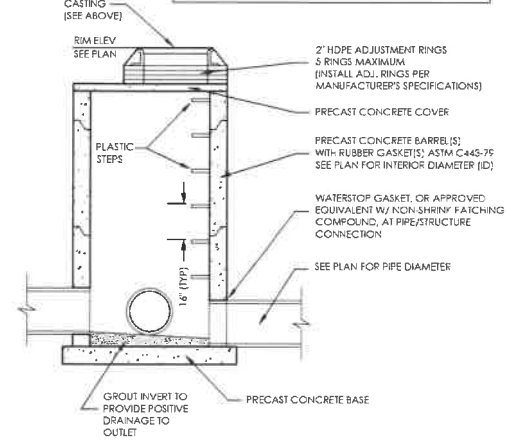

- NOTES**
- 1. SEE PLAN FOR INTERIOR DIAMETERS (ID) OF PRECAST CONCRETE BARREL SECTIONS
  - 2. SEE PLAN FOR PIPE CUT-OUT SECTIONS
  - 3. CONSTRUCT GROUDED FLOW LINES WITHIN STRUCTURE TO DIRECT FLOW TO OUTLET WITH NON-SHRINK GROUT
  - 4. FILL ANNULAR SPACE BETWEEN PIPE AND BARREL WITH NON-SHRINK GROUT.
  - 5. PRECAST CONCRETE COVERS, BARREL SECTIONS, AND BASES SHALL MEET THE REQUIREMENTS OF STANDARD MNDOT PLATES 4011 AND 4020
  - 6. PLASTIC STEPS SHALL BE AS PER MNDOT STANDARD PLATE 4180 AND SHALL BE PLACED OVER THE OUTLET PIPE

4 STORM MANHOLE OR CATCH BASIN NTS

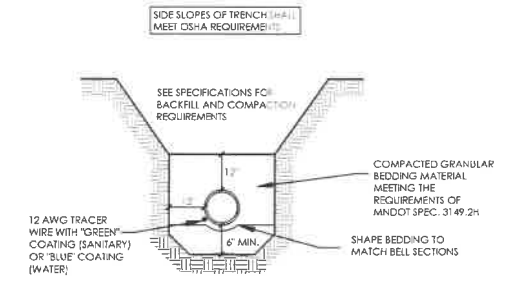

1 PIPE BEDDING DETAIL NTS

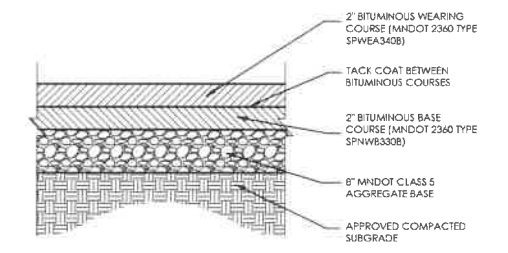

5 HEAVY-DUTY BITUMINOUS PAVEMENT SECTION NTS

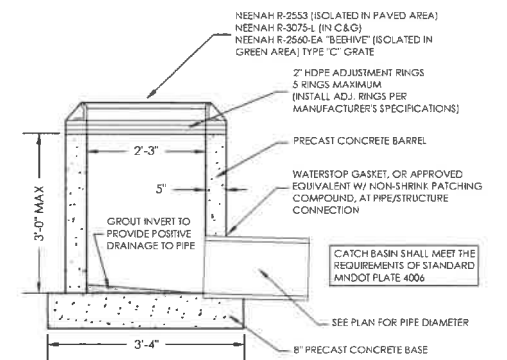

2 CATCH BASIN (MNDOT DESIGN "H") NTS

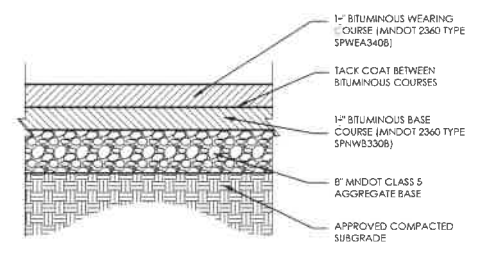

6 LIGHT-DUTY BITUMINOUS PAVEMENT SECTION NTS

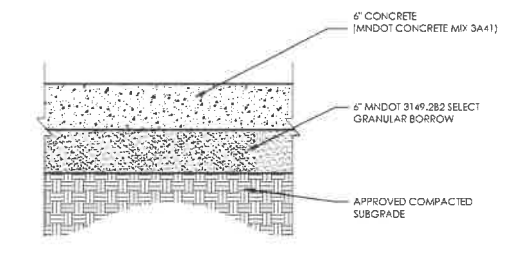

3 CONCRETE APRON/PAVEMENT SECTION NTS

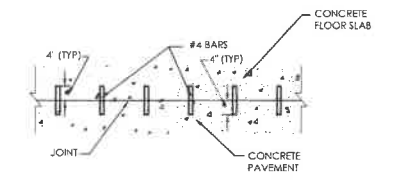

- NOTES**
- 1. REINFORCEMENT SHALL BE PROVIDED AT ALL BUILDING ENTRANCES WHERE CONCRETE APRONS OR PAVEMENT ABUT CONCRETE FLOOR SLABS
  - 2. BAR SPACING: 12" O.C. FOR 8" CONCRETE APRONS  
18" O.C. FOR 6" CONCRETE APRONS
  - 3. BARS SHALL BE PLACED AT THE CENTER OF THE THINNEST APRON OR SLAB, BUT SHALL HAVE A MINIMUM BAR COVER OF 3"
  - 4. BARS SHALL BE PLACED ACROSS TOTAL WIDTH OF BUILDING ENTRANCE

7 PAVEMENT/FLOOR SLAB JOINT REINFORCEMENT NTS

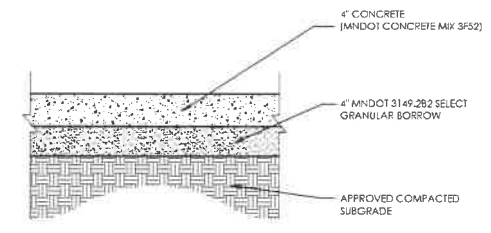

CONTRACTION AND EXPANSION JOINTS SHALL BE CONSTRUCTED AS PER MNDOT SPEC. 2521.3C2

8 CONCRETE SIDEWALK SECTION NTS

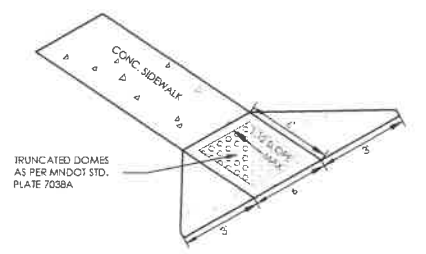

9 ADA PEDESTRIAN RAMP NTS

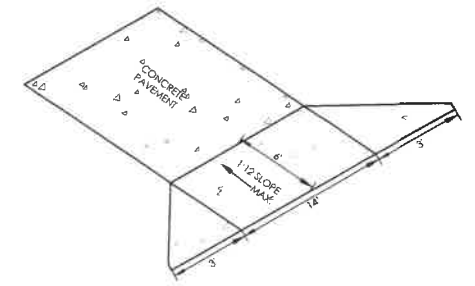

10 CONCRETE DRIVEWAY NTS

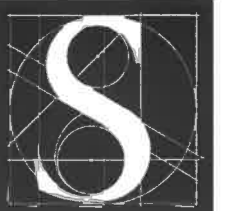

Sjoquist Architects, Inc  
2800 University Avenue SE, Suite 100  
Minneapolis, Minnesota 55414  
612.379.9253 Fax 612.379.9265  
http: www.sjoquist.com

SCHULTZ ENGINEERING & SITE DESIGN  
Suite 330  
18 South Riverside Avenue  
Sartell, MN 56377  
Ph: (320) 339-0669  
Fax: (866) 633-1830  
schultzeng@live.com  
www.schultzengineeringdesign.com

I hereby certify that this plan, specification or report was prepared by me or under my direct supervision and that I am a duly licensed Engineer under the laws of the state of Minnesota

BRIAN J. SCHULTZ, PE  
XX/XX/2020 43129  
DATE LICENSE NO.  
Revisions

1952  
Sjoquist Project Number  
20004  
Schultz Eng. Project Number

NEW BUILDING  
ADDITION  
AMERICAN  
POLYWATER  
CORPORATION

11222 60TH STREET NORTH  
STILLWATER,  
MINNESOTA

SCALE: 1" = 30'  
0 30 60  
GRADING PLAN

C-101.1

PRELIMINARY - NOT FOR CONSTRUCTION VEWID SUBMITTAL - 06/25/2020

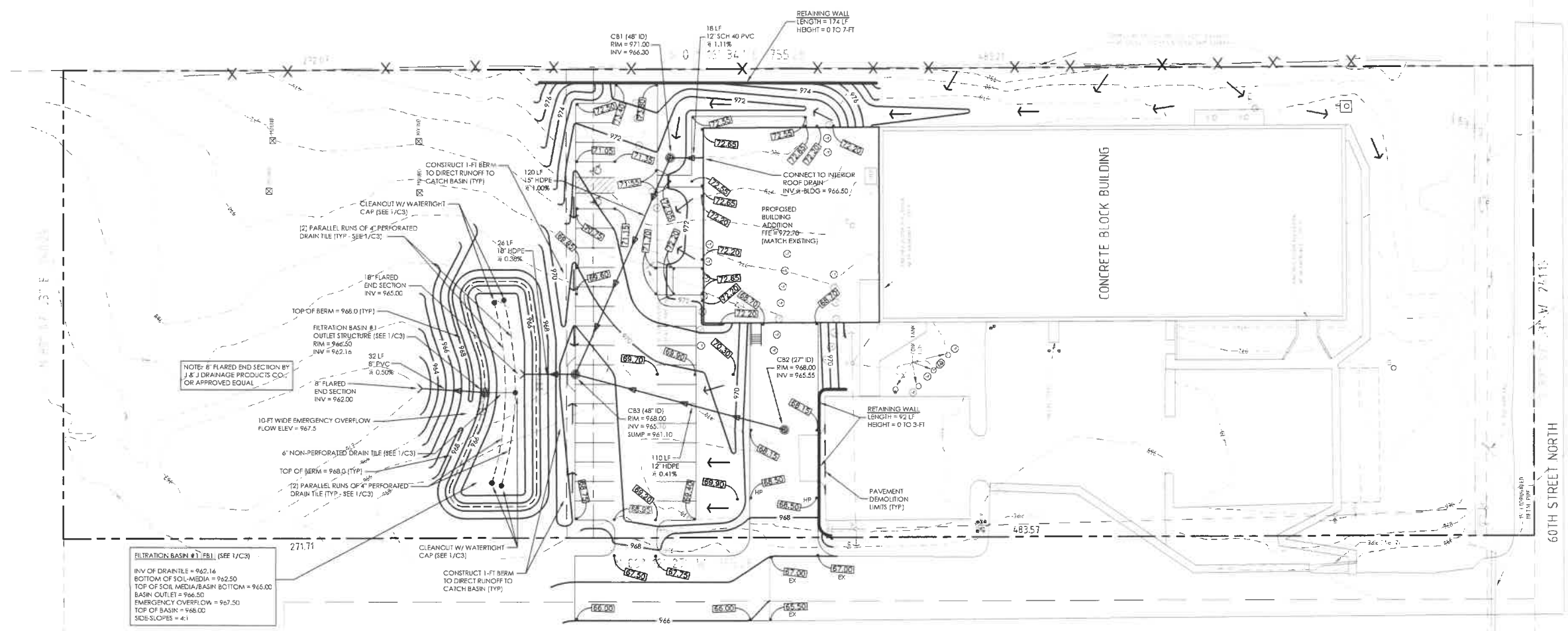

FILTRATION BASIN #1 (SEE 1/C/3)  
INV OF DRAIN TILE = 962.16  
BOTTOM OF SOIL MEDIA = 962.50  
TOP OF SOIL MEDIA/BASIN BOTTOM = 965.00  
BASIN OUTLET = 966.50  
EMERGENCY OVERFLOW = 967.50  
TOP OF BASIN = 968.00  
SIDE SLOPES = 4:1

NOTE: EXISTING DRIVEWAY DRAINS TO PAVED SWALE, WHICH DRAINS EXISTING UNLOADING DOCKY AREA OF NEARBY EXISTING BUILDING LOCATED TO THE WEST OF THE SITE. THIS DRAINAGE IS ROUTED NORTH TO EXISTING VEGETATED SWALE AND LOW AREAS LOCATED DOWNSTREAM. NEW DRIVEWAY EXTENSION SHALL DRAIN TO, AND BE INTO, EXISTING VEGETATED SWALE. CONTRACTOR SHALL FIELD VERIFY EXISTING ELEVATIONS IN VICINITY OF NEW DRIVEWAY EXTENSION.

GENERAL GRADING NOTES:

- 1. CONTRACTOR SHALL VERIFY ALL EXISTING CONDITIONS INCLUDING LOCATIONS, AND RIM AND INVERT ELEVATIONS, OF EXISTING DRAINAGE AND SANITARY STRUCTURES. LOCATION AND SEE OF EXISTING SANITARY, WATER, AND STORM SEWER STUBS, AND EXISTING GRADES SHALL ALSO BE VERIFIED.
- 2. EXISTING TOPOGRAPHICAL INFORMATION WAS OBTAINED FROM A TOPOGRAPHICAL SURVEY COMPLETED BY LANDMARK SURVEYING, INC. SCANDIA, MN. (651) 433-9421
- 3. BENCHMARK: CONTACT LANDMARK SURVEYING, INC.
- 4. NOTIFY ENGINEER IMMEDIATELY IF ANY INCONSISTENCIES ARE DISCOVERED BETWEEN ACTUAL SITE CONDITIONS AND WHAT IS SHOWN ON THE PLANS, WHICH ARE SIGNIFICANT ENOUGH TO ALTER THE DRAWINGS.
- 5. IF REQUIRED BY THE MINNESOTA DEPARTMENT OF LABOR AND INDUSTRY, THE OWNER OR CONTRACTOR SHALL OBTAIN A PLUMBING PERMIT PRIOR TO THE INSTALLATION OF ANY STORM SEWER UTILITIES.
- 6. THE CONTRACTOR SHALL CONTACT Gopher One Call AT (800) 252-1-66 FOR A UTILITY LOCATE PRIOR TO THE START OF CONSTRUCTION AND VERIFY LOCATIONS OF UTILITIES BEFORE BEGINNING WORK.
- 7. SEE SHEET C2 FOR STANDARD DETAILS.
- 8. ALL LENGTHS OF STORM SEWER OR CULVERT PIPE SPECIFIED ON THIS PLAN INCLUDE THE LENGTHS OF ANY ASSOCIATED FLARED END SECTIONS.
- 9. TRASH GUARDS SHALL BE INSTALLED ON ALL STORM SEWER END SECTIONS.
- 10. FINISHED ELEVATIONS OF LAWN/GREEN AREAS ADJACENT TO BUILDINGS SHALL BE A MINIMUM OF 6" BELOW FINISHED FLOOR OR TOP-OF-BLOCK ELEVATION.

FILTRATION BASIN NOTES:

- 1. TRAFFIC FROM CONSTRUCTION EQUIPMENT SHALL BE LIMITED AS MUCH AS POSSIBLE ACROSS FILTRATION BASIN AREAS, AND BE ONLY LOW IMPACT TRACK EQUIPMENT. BASIN AREAS SHALL BE EXCAVATED WITH A BACKHOE STATIONED OUTSIDE OF THE AREA AS MUCH AS POSSIBLE.
- 2. DURING CONSTRUCTION OF THE ADJACENT PARKING LOT AND BUILDING, THE FILTRATION BASIN AREA SHALL BE PROTECTED FROM TRAFFIC AND SEDIMENT WITH SILT FENCE. SEE SHEET C5.
- 3. FILTRATION SOIL MEDIA SHALL CONSIST OF MN STORM WATER MANUAL MIX "C" WITH IRON ENHANCEMENT (PERCENTAGES OF MATERIALS ARE BY VOLUME):
  - 6 1/8" TO 80# SAND (USDA SOIL TEXTURAL CLASSIFICATION)
  - 7% TO 10% FINE (SILT AND CLAY, WITH A MAXIMUM CLAY CONTENT OF 5%)
  - 3% TO 5% MNDOT 3890 GRADE 2 COMPOST
  - 5% TO 7% IRON FILINGS
- 4. ONCE THE FILTRATION BASIN HAS BEEN EXCAVATED AND BACKFILLED WITH SOIL MEDIA, THE CONTRACTOR SHALL ARRANGE AND PAY FOR TESTING THE INFILTRATION RATE OF THE SOIL MEDIA. THE TEST RESULTS SHALL BE SUBMITTED TO THE WATERSHED DISTRICT AND THE ENGINEER.
- 5. IN ORDER TO PASS, INFILTRATION TESTING RESULTS SHALL BE IN A SATURATED STATE AND MUST BE NO LESS THAN DOUBLE THE DESIGN RATE. FOR THIS PROJECT, THE DESIGN INFILTRATION RATE FOR THE FILTRATION BASIN IS 0.8-IN/HR. THIS INFILTRATION TEST RESULTS MUST BE NO LESS THAN 1.6-IN/HR.
- 6. ONCE EXCAVATED TO FINAL GRADE FILTRATION BASIN AREAS SHALL BE INSPECTED TO ENSURE THAT NO SEDIMENT FROM ONGOING CONSTRUCTION ACTIVITY IS REACHING THE BASIN AREAS. ALL FILTRATION BASIN AREAS SHALL BE INSPECTED TO ENSURE THAT UNAUTHORIZED EQUIPMENT IS NOT BEING DRIVEN ACROSS THE BASIN AREAS, AS WELL.
- 7. FINAL STABILIZATION OF THE FILTRATION BASINS SHALL NOT BE COMPLETED UNTIL THE UPSTREAM DRAINAGE AREAS HAVE BEEN STABILIZED.

NOTE: CADD FILES FOR ESTIMATING EARTHWORK QUANTITIES ARE AVAILABLE TO CONTRACTORS FOR PREPARING BIDS. IN ORDER TO RECEIVE THE CADD FILES, THE CONTRACTOR WILL NEED TO SIGN A HOLD-HARMLESS AGREEMENT PROVIDED BY SCHULTZ ENGINEERING & SITE DESIGN, AND AGREE TO PAY A \$50 PROCESSING FEE. THE CADD FILES WILL BE RELEASED UPON RECEIPT OF THE CHECK.

FILTRATION BASIN ELEVATIONS

FILTRATION BASIN	DRAIN TILE INVERT	SOIL MEDIA BOTTOM	BASIN BOTTOM	OVERFLOW GRATE	TOP OF BERM
F#1	962.16	962.50	965.00	966.50	968.00

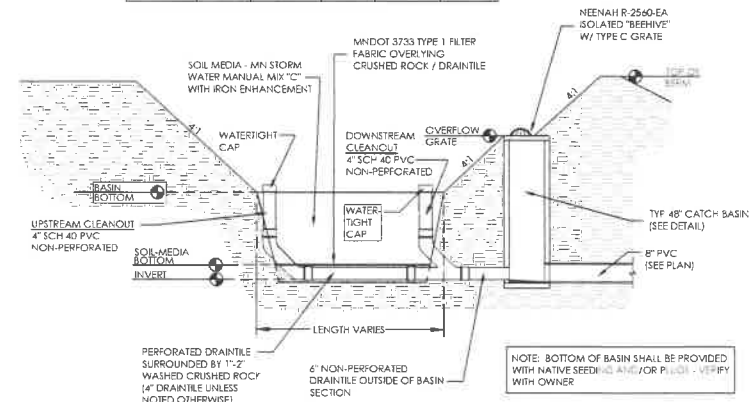

NOTE: MAINTENANCE OF THE FILTRATION BASIN, INCLUDING MOWING, WEED CONTROL, ETC., SHALL BE THE RESPONSIBILITY OF THE OWNER

NOTE: BOTTOM OF BASIN SHALL BE PROVIDED WITH NATIVE SEEDING AND/OR PLANT - VERIFY WITH OWNER

1 FILTRATION BASIN

NTS



Sjoquist Architects, Inc.
2800 University Avenue SE, Suite 100
Minneapolis, Minnesota 55414
612.379.9233 Fax 612.379.9263
http: www.sjoquist.com

SCHULTZ ENGINEERING & SITE DESIGN
18 South Riverside Avenue
Suite 230
Scarlet, MN 56377
Ph: (326) 339-0649
Fax: (866) 633-7830
schultzeng@live.com
www.schultzengineeringdesign.com

I hereby certify that this plan, specification or report was prepared by me or under my direct supervision and that I am a duly licensed Engineer under the laws of the state of Minnesota

BRIAN J. SCHULTZ, PE
XX/XX/2020 43129
DATE LICENSE NO.

Revisions
1952 Sjoquist Project Number
20004 Schultz Eng. Project Number

NEW BUILDING ADDITION
AMERICAN POLYWATER CORPORATION

11222 60TH STREET NORTH

STILLWATER, MINNESOTA

SWPPP - NOTES

C-101.2

PROJECT INFORMATION

Project Description

This project will consist of the construction of a new addition to an existing commercial building, with an approximate footprint of 9,000 sf, as well as parking lot and driveway areas, loading dock areas, and sidewalk. Storm water management for this project will consist of a filtration basin with ion enhancement.

Disturbed Area & Impervious Surface Tabulation (within proposed construction area)

Table with 2 columns: Category and Area. Rows include Anticipated Disturbed Area (1.5 acres), Existing Impervious Area (0.05 acres), Proposed Impervious Area (0.72 acres), and Net Impervious Area Increase (0.67 acres).

Permanent Site Drainage

Site drainage will be routed to a filtration basin via surface drainage and storm sewer to be constructed on site. The filtration basin has been designed to treat drainage from 1.1" of runoff off new impervious surfaces as per Valley Branch Watershed District requirements. The filtration basin includes soil media consisting of M1 Storm Water Manual Mix "C" with ion enhancement to provide for 75% phosphorus removal. For large events, the basin has been provided with an outlet structure, which will route treated storm water off site to the north. Some storage has been included in the basin for rate control. The basin has been designed to limit discharges to existing runoff rates from the 2, 10, and 100-year, 24-hour storm events, as well as the 100-year snowmelt event.

FILTRATION BASIN CALCULATIONS

Table with 2 columns: Description and Value. Rows include Total proposed impervious surface (31,300 SF), Required water quality volume (2,870 cf), Filtration Basin Area (963 contour), and Provided filtration volume (4,440 cf).

Receiving Surface Waters

The following surface waters could receive storm water runoff from this project, and are within 1 mile of the project site:

Table with 6 columns: Surface Water, Type of Surface Water, Impaired Water?, Special Water?, USEPA Approved TMDL for Impaired Water?, and Comments. Rows include Downstream Wetlands and various water bodies.

SEDIMENT AND OTHER POLLUTANTS

This SWPPP has been designed mainly to provide erosion and sediment control of naturally occurring soils at this site (ie: sands, loams, and clays). Although this SWPPP does address pollution prevention of other man-made materials, it is assumed that these materials will consist of debris from existing structures and pavements to be demolished, or debris and chemicals (ie: fuels, new paints, etc.) resulting from new construction.

There are no known solid wastes or hazardous materials buried below grade at this site. If such wastes or hazard materials are discovered during construction, the SWPPP Coordinator (described below) will be responsible for notifying the Engineer. This SWPPP will then be revised to address the presence and disposal of these additional pollutants.

EROSION PREVENTION AND SEDIMENT CONTROL RESPONSIBILITIES

SWPPP Design Engineer and Qualifications

Table with 2 columns: Design Engineer/Training Course/Instructor and Qualifications. Rows include Brian J. Schultz, PE and John Chapman.

SWPPP Coordinator and Qualifications

The Contractor shall provide an individual who shall serve as the SWPPP Coordinator for this project. The SWPPP coordinator shall oversee the implementation of this SWPPP, as well as the necessary inspections (described below) of erosion prevention and sediment control BMPs. The SWPPP Coordinator shall also oversee the installation, maintenance, and repair of the BMP's to be completed in accordance with this SWPPP. The SWPPP Coordinator shall be responsible for the items listed above during the period from the start of the project to the establishment of final stabilization. During this period, the SWPPP Coordinator, or their assigned, qualified (see below) representative shall be available for on-site inspection within 72 hours upon request by the MPCA.

It shall be the Contractor's responsibility to complete the table below, which will identify the SWPPP Coordinator and that person's qualifications. This person shall acknowledge that he/she has been assigned to serve as SWPPP Coordinator and will be overseeing the items listed in this section, by providing their signature in the space below. Please note that this SWPPP will not be considered complete if the table below is not filled in.

\* Typically, the identity of the SWPPP Coordinator is unknown until the project is awarded. The SWPPP Coordinator may be identified at the project's Preconstruction Conference.

Table for SWPPP Coordinator information, including Company Name, Office Phone #, Cell Phone #, Training Course, and Instructor. Includes a signature line and date field.

The SWPPP Coordinator may assign other personnel to supervise or perform the duties listed above. However, in completing the duties listed above, at least one person shall be trained in erosion prevention and sediment control as related to that particular part of the SWPPP.

If the SWPPP Coordinator chooses to delegate some of the duties and responsibilities listed above to other personnel, a list of the personnel, as well as their qualifications, shall be kept with and shall become part of this SWPPP. The qualifications shall be documented in a manner similar to the table shown above. A copy of this list shall be provided to the Engineer.

Once the project has been completed and accepted by the Owner, and Final Stabilization has been established and Notice of Termination submitted to the MPCA, the Owner assumes responsibility for the long term maintenance of this storm water management system.

The SWPPP Coordinator shall be responsible for ensuring that the Contractor properly disposes of the temporary erosion and sediment control measures within 30 days after site stabilization is achieved or after the temporary measures are no longer needed.

Record Retention

The SWPPP and associated records shall be stored and maintained by an employee or representative of the Owner for 3 years after the submission of the Notice of Termination (NOT). Responsibility for overseeing the records will be transferred to another employee or representative should the current personnel become uninvolved with the project or Owner. These records shall include the following:

- 1). The final SWPPP
2). Any other stormwater related permits required for the project
3). Records of all inspection and maintenance conducted during construction
4). All permanent operation and maintenance agreements that have been implemented, including all right-of-way, contracts, covenants and other binding requirements regarding perpetual maintenance
5). All required calculations for design of the temporary and permanent Stormwater Management Systems.

BMP INSPECTIONS

Inspection Frequency

The SWPPP Coordinator shall inspect, or designate someone else who is qualified to inspect (see above), the construction site erosion prevention and sediment control BMPs per the following time frames:

- 1). Once every 7 days
2). Within 24 hours of a rain event (1/2" or greater over 24 hours)
Inspections shall be conducted per the time frames listed above with the following exceptions:
1). Where parts of the construction site have permanent cover, but work remains on other parts of the site, inspections of areas with permanent cover may be reduced to once per month
2). Where construction sites have permanent cover on all exposed soil areas and no construction activity is occurring anywhere on the site, the site must be inspected for a period of 12 months (inspections may be suspended during frozen ground conditions). Following the 12-month period of permanent cover, inspections may be terminated until construction activity is once again initiated or sooner if notified in writing by the MPCA.
3). Where work has been suspended due to frozen ground conditions, the required inspections and maintenance schedule must begin within 24 hours after runoff occurs at the site or prior to resuming construction, whichever occurs first.

Inspection Records

The SWPPP Coordinator shall maintain inspection records during construction. These must be recorded in writing within 24 hours of the inspection and/or maintenance activity. The inspection records shall include the following:

- 1). Date and time of inspection
2). Name of person(s) conducting inspection
3). Findings of inspections, including recommendations for corrective actions
4). Corrective actions taken (including dates, times, and party completing maintenance activities)
5). Date and amount of any rainfall events greater than 1/2" in 24 hours
6). If any discharge is observed to be occurring during the inspection, a record of all points of the property from which there is a discharge must be made, and the discharge shall be described (ie: color, odor, floating, settled, or suspended solids, foam, oil, sheen, and other obvious indicators of pollutants) and photographed.
7). Documentation of any changes to the SWPPP made during construction
a). If the SWPPP coordinator observes that a BMP fails on a regular basis and believes that it is ineffective, it shall be his/her responsibility to notify the Engineer of such deficiencies. The Engineer may then amend the SWPPP (see "Amending the SWPPP")
Note: Copies of all inspection records shall be submitted to the Engineer.

AMENDING THE SWPPP

During the construction of this project it may become necessary to amend this SWPPP. Should the responsibility of installing, inspecting and maintaining the erosion and sediment control devices and techniques described in this SWPPP be transferred from the current Contractor to another Contractor, or from the current Contractor to the Owner, this SWPPP shall be updated accordingly. The Owner will also be required to complete an "Permit Modification Form".

Should it be determined, during construction, by the SWPPP Coordinator, Engineer, or Regulatory Official that deficiencies in this SWPPP exist, or if significant changes are made to the design/significance of this project that impact erosion prevention and sediment control, the Engineer will be notified immediately. The Engineer will then review potential deficiencies and/or significant changes to project design/scope, and make necessary changes to the SWPPP.

After changes are made to the SWPPP, the Engineer will issue the necessary communication, reflecting the changes, to the owner, and to the SWPPP Coordinator. The SWPPP Coordinator shall be responsible to make sure that this documentation is added to the on-site SWPPP copy and that the changes described in the communication is implemented on-site.

EROSION PREVENTION AND SEDIMENT CONTROL BMPs

Standards and References

Materials and construction methods of all BMPs included in this SWPPP shall be as per the Minnesota Department of Transportation (MNDOT) Standard Specifications for Construction, latest edition. The Contractor and SWPPP Coordinator shall obtain a current copy of MNDOT Standard Specifications for Construction and familiarize themselves with the specification sections applicable to this SWPPP, as there are several BMPs that specifically reference these sections.

The Contractor and SWPPP Coordinator shall be expected to be familiar with the applicable MNDOT specification sections during construction. No additional compensation will be paid to the Contractor for additional work due to unfamiliarity with these specification sections.

Undisturbed Area

If shown on the plan, the Contractor shall delineate areas that are not to be disturbed on the site. This may be done with flags, stakes, signs, silt fence, etc., and shall be completed prior to the start of any grading operations. Regardless of the delineation method the Contractor chooses to use, the Contractor must communicate to his/her personnel and subcontractors that these areas are not to be disturbed and construction equipment (including trucks and personal vehicles) shall not be allowed in these areas.

The Contractor shall minimize compaction and preserve topsoil as much as possible at the site. In parvow, ["green"] areas that are not essential to the construction of the project, the Contractor shall avoid construction traffic and maintain the existing condition of these areas.

Temporary and Permanent Stabilization

All exposed soil areas (including stockpiles) shall be provided with temporary or permanent cover within 14 days of construction activity temporarily or permanently ceasing in that portion of the site. Temporary or permanent drainage ditches or swales, which drain all-site or to a surface water, and are within 200 linear feet of a property line or surface water shall be provided with temporary or permanent cover within 24 hours of construction. Placement of temporary or permanent cover shall be initiated immediately upon suspension or completion of excavation operations.

Temporary Cover:

If the Contractor chooses to halt grading operations in a portion of the site (or the whole site) for a period exceeding 14 days, and grading operations (rough or finish grading) in the affected areas has not yet been completed, temporary cover shall be placed. Affected areas consisting of drainage ditches or swales connected to, and within, 200 linear feet of a property line or surface water shall be provided with temporary cover within 24 hours of connection. Depending on the Contractor's schedule, the temporary cover shall consist of one of the following BMPs:

- 1). Disconnected Mutch
a). Disconnected mulch may be used in an area of the site (or the whole site) if the Contractor is halting grading operations for a period that is relatively short, but exceeds 14 days.
b). The mulch shall be Type 3e per MNDOT Spec. 3882
c). An adequate quantity of mulch shall be evenly distributed to achieve 90% coverage of the exposed soils.
d). Mulch shall be placed as per MNDOT 2575.3D.
e). All mulch shall be disc anchored as per MNDOT 2575.3D. Prior to the placement and disanchoring of the mulch, the soils shall be loosened and the area smooth-rough graded per MNDOT 2574.
2). Any areas that are exposed as a result of wind action after the initial mulch placement shall be covered with additional mulch to maintain 90% coverage.

Temporary Seeding with Mutch

- a). Temporary seeding with mulch may be used in areas of the site (or the whole site) if the Contractor is halting grading operations for a period that is relatively long. Although mulch still needs to be applied as described above, once the temporary seeding/mulch is established, the mulch will no longer need to be maintained. The temporary seeding/mulch will require very little maintenance.
b). Prior to the sowing of temporary seed, the soils shall be loosened and the area smooth-rough graded per MNDOT 2574.
c). Contractor shall utilize Seed Mixes 21-111, 21-112, or 21-113 per MNDOT Spec. 3876 for temporary seeding.
d). Temporary seeding shall be sown per MNDOT Spec. 2575.3B.
e). Once temporary seeding has been sown, mulch shall be placed over the area as described above.

Permanent Cover:

Upon completion of finish grading and/or placement of topsoil, initiation of the placement of permanent cover shall begin immediately over all exposed areas. This includes areas designated for impervious surfacing (ie: buildings, pavements/grovel bases, sidewalks, etc.). Where the construction schedule will not allow for the placement of the permanent impervious surfacing within 14 days of the completion of finish grading, temporary cover shall be provided in these areas, as described above, until the permanent impervious surfacing can be constructed. Affected areas consisting of drainage ditches or swales connected to, and within, 200 linear feet of a property line or surface water, shall be provided with permanent cover within 24 hours of connection.

Areas designated for permanent turf establishment shall be provided with one or more of the following BMPs (see plan):

- 1). Permanent Seeding with Mutch
a). Unless otherwise noted on the plans, all areas designated for turf establishment shall be provided with permanent seeding
b). In addition to the plan included as part of this SWPPP, the Contractor shall verify if a Landscaping Plan has been included in the plans by the Architect. If a Landscape Architect has specified Higher quality permanent cover (ie: sod, hydroseeding, etc.), the Contractor shall provide this permanent cover in lieu of the permanent seeding specified in this SWPPP.
c). Prior to the sowing of permanent seed, the soils shall be loosened and the area smooth-rough graded per MNDOT 2574.
d). Contractor shall utilize Seed Mix 20-131 per MNDOT Spec. 3876 for permanent seeding.
e). Permanent seeding shall be sown per MNDOT Spec. 2575.3B.
f). Once permanent seeding has been sown, mulch shall be placed over the area as described above (unless Temporary Cover), unless noted otherwise.

Erosion Control Blanket

- a). Erosion control blanket shall be placed in areas as shown on the plan included in this SWPPP. These areas shall still be provided with permanent seeding, as described above, beneath the erosion control blanket.
b). Erosion control blanket shall meet the requirements indicated in MNDOT Spec. 3883. See plan for category(s) of erosion control blanket.
c). Erosion control blanket shall be installed as per MNDOT Spec. 2575.3D2.
d). Erosion control blanket specified in drainage ditches and swales connected to, and within 200 linear feet, of a property line or surface water shall be installed within 24 hours of the completion of finish grading (including permanent seeding).

Riprap

- a). Riprap shall be placed in areas as shown on the plan included in this SWPPP.
b). All riprap shall be underlain with Type 4 geotextile fabric. The fabric shall meet the requirements of MNDOT Spec. 3733 and shall be installed as per MNDOT Spec. 2511.3B2.
c). Riprap materials shall meet the requirements of MNDOT Spec. 3601, and shall be Class 3, unless noted otherwise on the plans.
d). Riprap shall be considered "Random Riprap" and shall be placed as per MNDOT Spec. 2511.
e). Although it is permitted for the riprap to be placed with machinery, it will be necessary for the Contractor to hand place some of the riprap in order to provide a dense, well-keyed layer of stones with the least practical quantity of void space.
f). The minimum thickness of the riprap shall be 18 inches, unless otherwise noted on the plans.
g). Riprap designated at the end of pipe outlets shall be placed within 24 hours of installation of the pipe outlet and section.
h). Riprap specified in drainage ditches and swales connected to, and within 200 linear feet, of a property line or surface water shall be installed within 24 hours of the completion of finish grading.

Sediment Control

The following sediment control BMPs shall be implemented as part of this project:

- 1). Silt Fence
a). Silt fence shall be installed at the locations shown on the plan included in this SWPPP.
b). Silt fence shall be machine sliced and materials shall meet the requirements of MNDOT Spec. 3886.
c). Silt fence shall be installed as per MNDOT Spec. 2573.3B2.
d). Silt fence shall be installed prior to any upgradient grading operations, and shall remain in place and maintained adequately until upgradient areas achieve Final Stabilization (see below)
e). Silt fence shall be repaired or replaced if damaged during, or after, rain events, or if accumulated sediment on the upstream side of the fence reaches 1/3 of the height of the fence. Repair or replacement of silt fence shall be completed within 24 hours of discovery.
f). Portions of silt fence may be removed to accommodate short-term activities, such as vehicle passage. Short-term activities shall be completed as quickly as possible, and new silt fence installed immediately after completion of the short-term activity. If rainfall is imminent or forecasted in the near future, new silt fence shall be installed regardless of if the short term activity has been completed or not. The Contractor is advised to schedule short term activities during dry weather as much as practicable. No additional compensation will be paid due to additional silt fence associated with short-term activities.

- a). Temporary soil stockpiles shall be placed on the site in areas upgradient from silt fence. Where the Contractor chooses to place temporary soil stockpiles outside designated silt fenced areas, the stockpiles shall be surrounded by additional silt fence. Under no circumstances shall temporary soil stockpiles be placed over surface water, curb and gutter, catch basins, culvert inlets or outlets, or ditches.
2). Catch Basin Protection

- a). WMCO Road Drain protection devices, as manufactured by WMCO, shall be used for catch basin protection on this project. WMCO can be contacted at (952)-233-3053, and their web page is www.roadrain.com.
b). "Road Drain Top Slab" devices shall be installed at all catch basin locations immediately after placement of the catch basin structures. "Road Drain Top Slab" devices shall remain in place and be adequately maintained until permanent surfacing is constructed (ie: curb and gutter, pavements, and/or gravel surfacing). In areas designated for turf establishment, "Road Drain Top Slab" devices shall remain in place until Final Stabilization of all upgradient areas is established.
c). Upon construction of the permanent surfacing, the "Road Drain Top Slab" devices shall be replaced with the WMCO product specified on the plans. The WMCO devices shall remain in place until Final Stabilization of all upgradient areas has been established.

- a). The contractor shall install and maintain the catch basin protection devices as per the manufacturer's instructions and specifications.

Culvert Inlet Protection

- a). Culvert inlet protection shall be provided at all culvert inlet locations immediately after construction of the culvert. See plan included in this SWPPP for culvert inlet locations.
b). Culvert inlet protection shall consist of geotextile fabric wrapped around, and completely covering the inlet end section. The geotextile fabric shall be the same fabric used in silt fence applications and meet the requirements of MNDOT Spec. 3886.
c). The culvert inlet protection shall remain in place and adequately maintained until Final Stabilization of all upgradient areas has been established.
d). Culvert inlet protection shall be repaired or replaced if damaged during, or after, rain events, or if accumulated sediment reaches 1/2 of the diameter of the culvert pipe. Repair or replacement of culvert inlet protection shall be completed within 24 hours of discovery.

Temporary Rock Construction Entrance

- a). Temporary rock construction entrances shall be installed at the locations shown on the plan included in this SWPPP. See detail for temporary rock entrance design
b). If the Contractor chooses to access the site from locations other than where temporary rock entrances are specified on the plan, additional temporary rock entrances shall be placed at these locations, as well.
c). Temporary rock entrance shall be constructed prior to the start of grading operations, and shall remain in place and be adequately maintained until Final Stabilization has been established.
d). Temporary rock entrances shall be maintained in such a manner that the entrances prevent sediment tracking onto adjacent streets. If a temporary rock entrance is found to be ineffective, it shall be replaced or improved within 24 hours of discovery.
e). The Contractor shall be required to place Type 4 geotextile fabric beneath the temporary rock entrance. The fabric may extend the life of the entrance as well as reduce rock "sinking" into the underlying soils. If the Contractor chooses to use fabric, it should meet the requirements of MNDOT Spec. 3733 and shall be installed as per MNDOT Spec. 2511.3B2.
f). If sediment tracking from the site is discovered on adjacent streets, the sediment shall be removed with a street sweeper or other approved method within 24 hours of discovery. This shall be done throughout construction of the project. The sediment may be returned and graded over exposed areas of the site, or disposed of off site per MPCA requirements.

The City may order street sweeping to be performed if the Contractor's or Owner's expense if City staff find that construction activities are resulting in sediment or debris being tracked onto City streets.

Filter Logs

- a). Filter logs shall be installed at the locations shown on the plan included in this SWPPP.
b). Filter logs shall consist of Type Wood Fiber burlap and meet the requirements of MNDOT Spec. 3857.
c). Filter logs shall be installed as per MNDOT Spec. 2573.3f.
d). Filter logs shall be installed immediately after placement of erosion control blanket.
e). Filter logs shall remain in place for the life of the project, and shall be allowed to degrade naturally.

Dewatering

If dewatering of sandy substrata is required for this project, the pump discharge shall be located prior to discharge off-site or into a surface water. Treatment of discharge shall be achieved with the use of a "Dandy Dewatering Bag" (or approved equivalent), as manufactured by Dandy Products, Inc. Dandy Products, Inc. can be contacted at (877) 307-0141, and their web page is www.dandyproducts.com. The "Dandy Dewatering Bag" shall be installed, utilized, and maintained per the manufacturer's instructions and specifications.

Once dewatering water has been treated, it may be discharged off-site or to a surface water. The discharge shall be visually checked to ensure that it is relatively clean and not visibly different from any receiving waters. If discharge is noticeably "dirty", the Engineer shall be contacted as additional treatment methods may be necessary.

Adequate erosion control shall be provided at the point of discharge if it is located in an area with exposed soils or established turf. This erosion control may consist of temporary seeding, rip rap, or other approved energy dissipation measures. The type of erosion control measure shall be at the Contractor's discretion, depending on the location of the dewatering discharge and the unique site characteristics. The erosion control measures must be effective and shall be maintained adequately such that no erosion occurs at the point of discharge.

Pollution Prevention Management

Solid waste accumulated during construction, including collected sediment, construction materials, roofing debris, construction debris, paper, plastics, and other solid wastes shall be disposed of in accordance with MPCA disposal requirements:

- 1). Building products that have the potential to leach pollutants shall be maintained under cover (e.g., plastic sheeting or temporary roof) to prevent the discharge of pollutants or protected by a similarly effective means designed to minimize contact with storm water.
2). Pesticides, herbicides, insecticides, fertilizers, treatment chemicals, and landscape materials shall be maintained under cover (e.g., plastic sheeting or temporary roof) to prevent the discharge of pollutants or protected by similarly effective means designed to minimize contact with stormwater.
3). Hazardous materials, toxic waste, including oil, diesel fuel, gasoline, hydraulic fluids, paint solvents, petroleum-based products, wood preservatives, additives, curing compounds, and acids) shall be properly stored in sealed containers to prevent spills, leaks or other discharge. Restricted access storage areas shall be provided to prevent vandalism. Storage and disposal of hazardous waste or hazardous materials shall be in compliance with Minn. R. ch. 7045 including secondary containment as applicable.
4). Solid waste shall be stored, collected and disposed of properly in compliance with Minn. R. ch. 7033.
5). Portable toilets shall be positioned so that they are secure and will not be tipped or knocked over. Sanitary waste must be disposed of properly in accordance with Minn. R. ch. 7041.

The Contractor shall take steps to prevent the discharge of spilled or leaked chemicals, including fuel, from any area where chemicals or fuel will be loaded or unloaded including the use of drip pans or absorbents unless infeasible. The Contractor shall contain fueling in a contained area unless infeasible. The Contractor shall ensure adequate supplies are available at all times to clean up discharge materials and that an appropriate disposal method is available for recovered spilled materials. The Contractor shall report and clean up spills immediately as required by Minn. Stat. § 115.041, using dry clean up measures where possible.

If the Contractor washes the exterior of vehicles or equipment on the project site, washing shall be limited to a defined area of the site. Runoff from the washing area shall be contained in a sediment basin or other similarly effective control and waste from the washing activity shall be properly disposed of. The Contractor shall properly use and store steps, dewatering, as defined. No engine degreasing shall be allowed on site.

The Contractor shall provide effective containment for all liquid and solid wastes generated by washout operations (concrete, stucco, paint, form release oils, curing compounds and other construction materials) related to the construction activity. The liquid and solid washout wastes shall not contact the ground, and the containment shall be designed so that it does not result in runoff from the washout operations or areas. Liquid and solid wastes shall be disposed of properly and in compliance with MPCA rules. A sign must be installed adjacent to each washout facility that requires site personnel to utilize the proper facilities for disposal of concrete and other washout wastes.

FINAL STABILIZATION

Final Stabilization shall be considered established once the following requirements have been achieved:

- 1). All soil disturbing activities of the site have been completed and all soils are stabilized by a uniform permanent vegetative cover with a density of 70 percent of its expected final growth density over the entire previous surface area, or other equivalent means necessary to prevent soil failure under erosive conditions.
2). The permanent storm water management system is constructed, and is operating as designed. Temporary or permanent sedimentation basins that are to be used as permanent water quality management basins have been cleaned of any accumulated sediment. All sediment has been removed from conveyance systems and ditches are stabilized with permanent cover.
3). All temporary synthetic and structural erosion prevention and sediment control BMPs have been removed from the project site. BMPs designed to decompose on site may be left in place.

ADDITIONAL COMMENTS

The Contractor is solely responsible for the cleanup of any wetlands, rivers, streams, lakes, reservoirs, other waters of the State (as defined by the MPCA's General Storm Water Permit), ground or roadway surfaces or other property damaged by construction activity related to this project.

Besides the NPDES permit (MPCA General Storm Water Permit), the Contractor and/or Owner shall also be responsible to obtain all other necessary local government permits related to storm water management, and erosion and sediment control, if applicable (ie: Watershed District, City, MNDOT, etc.).

This SWPPP is intended to provide a plan for addressing the erosion prevention and storm water management issues associated with this project. It is to be used in conjunction with the project plans, specifications, and the MPCA General Storm Water Permit. In addition to this SWPPP, the Owner, Contractor, and SWPPP Coordinator shall familiarize themselves with the actual requirements indicated in the MPCA General Storm Water Permit itself and are responsible for compliance with the permit's terms, requirements, and conditions. The Engineer can provide a copy of the permit upon request.

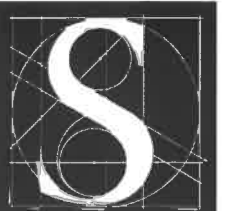

Sjoquist Architects, Inc  
2800 University Avenue SE, Suite 100  
Minneapolis, Minnesota 55414  
612.379.9233 Fax 612.379.9263  
http: www.sjoquist.com

SCHULTZ ENGINEERING & SITE DESIGN  
18 South Riverside Avenue  
Suite 230  
Scarlet, MN 56377  
Ph: (320) 339-0669  
F: (866) 433-1830  
schultzeng@live.com  
www.schultzengineeringdesign.com

I hereby certify that this plan, specification or report was prepared by me or under my direct supervision and that I am a duly licensed Engineer under the laws of the state of Minnesota

BRIAN J. SCHULTZ, PE  
XX/XX/2020 43129  
DATE LICENSE NO.  
Revisions

1952  
Sjoquist Project Number  
20004  
Schultz Eng. Project Number

NEW BUILDING  
ADDITION  
AMERICAN  
POLYWATER  
CORPORATION

11222 60TH STREET NORTH  
STILLWATER,  
MINNESOTA

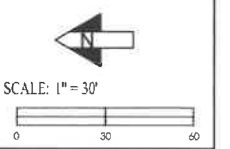

SWPPP - PLAN VIEW

C-101.3

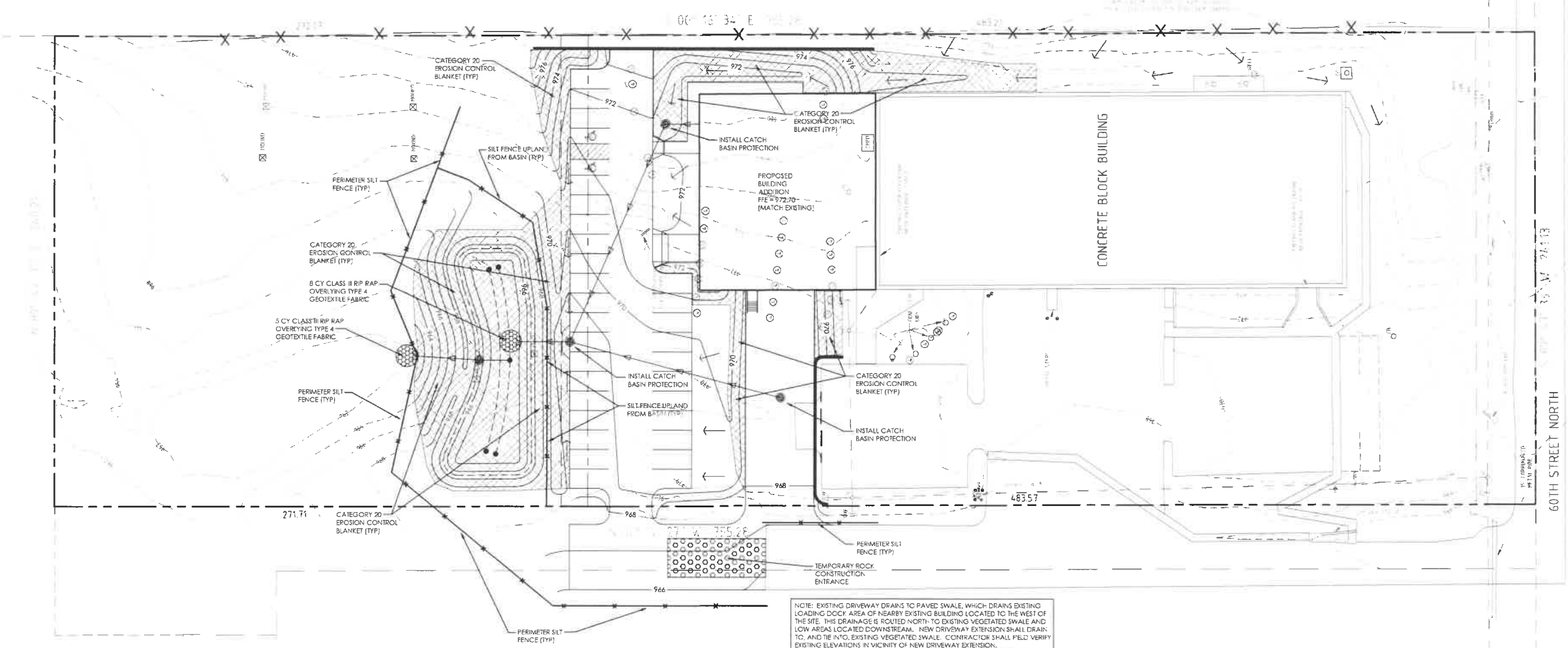

NOTE: EXISTING DRIVEWAY DRAINS TO PAVED SWALE, WHICH DRAINS EXISTING LOADING DOCK AREA OF HEAVY EXISTING BUILDING LOCATED TO THE WEST OF THE SITE. THIS DRAINAGE IS ROUTED NORTH TO EXISTING VEGETATED SWALE AND LOW AREAS LOCATED DOWNSTREAM. NEW DRIVEWAY EXTENSION SHALL DRAIN TO, AND TIE INTO, EXISTING VEGETATED SWALE. CONTRACTOR SHALL FIELD VERIFY EXISTING ELEVATIONS IN VICINITY OF NEW DRIVEWAY EXTENSION.

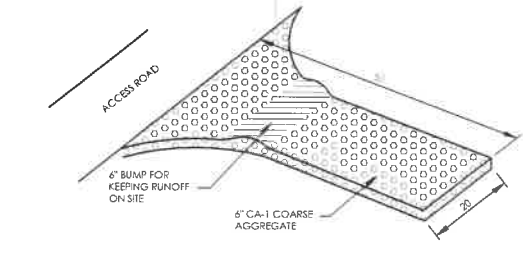

1. THE ROCK ENTRANCE SHALL BE CONSTRUCTED PRIOR TO THE START OF GRADING OPERATIONS.
2. THE ENTRANCE SHALL BE GRADED SUCH THAT POSITIVE DRAINAGE DURING CONSTRUCTION IS PROVIDED.
3. THE ENTRANCE SHALL BE MAINTAINED IN SUCH A CONDITION SUCH THAT IT PREVENTS MUD TRACKING OFF SITE. ADDITIONAL ROCK OR REPLACEMENT OF THE ENTRANCE MAY BE REQUIRED PERIODICALLY IF MUD STARTS TO TRACK OFF SITE.
4. THE ROCK ENTRANCE MAY BE REMOVED JUST PRIOR TO THE PLACEMENT OF AGGREGATE BASE.

NOTE: PLACING FILTER FABRIC UNDER THE ROCK ENTRANCE MAY REDUCE THE AMOUNT OF MAINTENANCE IT WOULD REQUIRE

1 TEMPORARY ROCK CONSTRUCTION ENTRANCE NTS

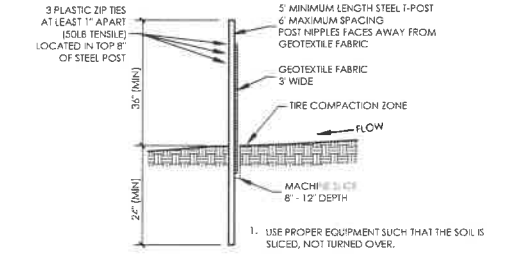

MATERIALS PER MNDOT 3886  
INSTALLATION PER MNDOT 2573.3C1

2 SILT FENCE (MACHINE SLICED) NTS

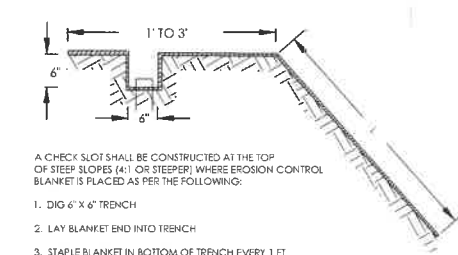

- A CHECK SLOT SHALL BE CONSTRUCTED AT THE TOP OF STEEP SLOPES (4:1 OR STEEPER) WHERE EROSION CONTROL BLANKET IS PLACED AS PER THE FOLLOWING:
1. DIG 6" X 6" TRENCH
  2. LAY BLANKET END INTO TRENCH
  3. STAPLE BLANKET IN BOTTOM OF TRENCH EVERY 1 FT
  4. BACKFILL TRENCH WITH SOIL AND COMPACT
  5. IF SLOPE LENGTH (L) IS GREATER THAN 100 FT DIG A CHECK SLOT 1/3 FROM THE BOTTOM OF THE SLOPE AND STAPLE THE BLANKET IN AS IN THE TOP TRENCH.

3 EROSION CONTROL BLANKET NTS

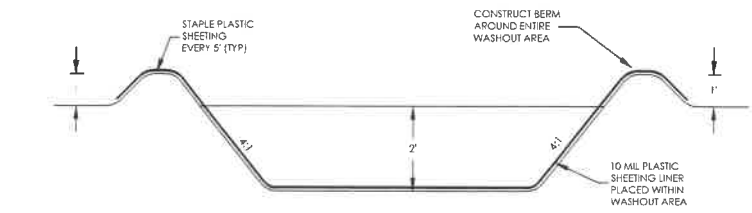

1. BOTTOM OF CONCRETE WASHOUT AREA SHALL BE 10'X10'
2. CONTRACTOR SHALL REMOVE WASH LIQUID FROM CONCRETE WASHOUT AREA AND DISPOSE OF PER MPCA REQUIREMENTS WHEN WASHOUT AREA BECOMES HALF FULL.
3. CONTRACTOR SHALL SELECT THE MOST OPTIMAL LOCATION FOR THE CONCRETE WASHOUT

4 CONCRETE WASHOUT NTS

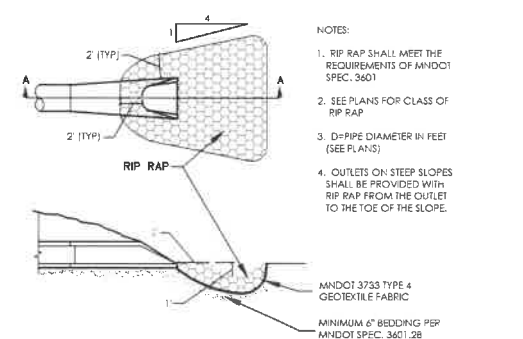

- NOTES:
1. RIP RAP SHALL MEET THE REQUIREMENTS OF MNDOT SPEC. 3601
  2. SEE PLANS FOR CLASS OF RIP RAP
  3. DI=PIPE DIAMETER IN FEET (SEE PLANS)
  4. OUTLETS ON STEEP SLOPES SHALL BE PROVIDED WITH RIP RAP FROM THE OUTLET TO THE TOE OF THE SLOPE.

5 RIP RAP AT PIPE OUTLETS NTS

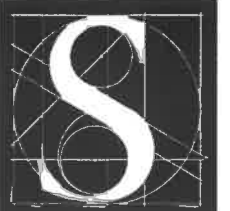

Sjoquist Architects, Inc  
2800 University Avenue SE, Suite 100  
Minneapolis, Minnesota 55414  
612.379.9233 Fax 612.379.9263  
http: www.sjoquist.com

SCHULTZ ENGINEERING & SITE DESIGN  
18 South Riverside Avenue  
Suite 230  
Scarlet, MN 56377  
Ph: (320) 339-0669  
Fax: (866) 633-1830  
schultzeng@ve.com  
www.schultzengineeringdesign.com

I hereby certify that this plan, specification or report was prepared by me or under my direct supervision and that I am a duly licensed Engineer under the laws of the state of Minnesota

BRIAN J. SCHULTZ, PE  
XX/XX/2020 43129  
DATE LICENSE NO.  
Revisions

1952  
Sjoquist Project Number  
20004  
Schultz Eng. Project Number

NEW BUILDING  
ADDITION  
AMERICAN  
POLYWATER  
CORPORATION

11222 60TH STREET NORTH  
STILLWATER,  
MINNESOTA

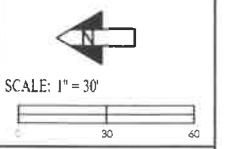

PAVING PLAN

C-102

PRELIMINARY - NOT FOR CONSTRUCTION VBWD SUBMITTAL - 06/25/2020

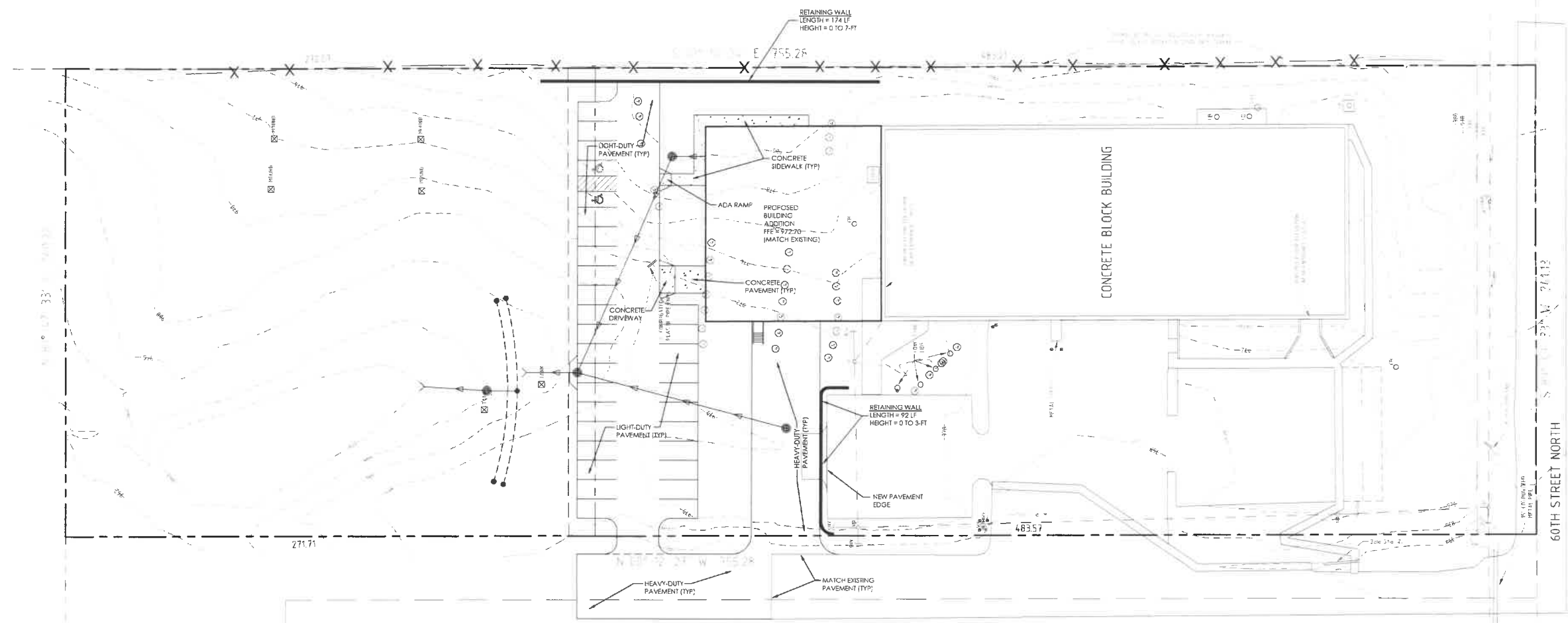

NOTE: EXISTING DRIVEWAY DRAINS TO PAVED SWALE, WHICH DRAINS EXISTING LOADING DOCK AREA OF NEARBY EXISTING BUILDING LOCATED TO THE WEST OF THE SITE. THIS DRAINAGE IS ROUTED NORTH TO EXISTING VEGETATED SWALE AND LOW AREAS LOCATED DOWNSTREAM. NEW DRIVEWAY EXTENSION SHALL DRAIN TO, AND TIE INTO, EXISTING VEGETATED SWALE. CONTRACTOR SHALL FIELD VERIFY EXISTING ELEVATIONS IN VICINITY OF NEW DRIVEWAY EXTENSION.

SURFACING NOTES:

1. SUBGRADES SHALL BE SCARIFIED AND/OR COMPACTED AS NECESSARY TO ATTAIN THE REQUIRED COMPACTION DESCRIBED IN THE GENERAL NOTES (SHEET C1). TEST ROLLING OF THE SUBGRADE SHALL BE OBSERVED BY A QUALIFIED GEOTECHNICAL ENGINEER OR TECHNICIAN. LOCATIONS EXHIBITING EXCESSIVE RUTTING (PER MNDOT SPEC. 2111) SHALL BE REPAIRED TO THE SATISFACTION OF THE ENGINEER PRIOR TO THE PLACEMENT OF AGGREGATE BASE. COMPACTION TESTING IN UTILITY TRENCHES SHALL BE PERFORMED BY AN INDEPENDENT TESTING FIRM.
2. GRAVEL BASE COURSES SHALL BE ROLLED AND COMPACTED. TEST ROLLING OF THE GRAVEL BASE SHALL BE OBSERVED BY A SOILS ENGINEER TO VERIFY STABILITY.
3. ALL EXISTING BITUMINOUS OR CONCRETE EDGES, WHICH WILL ABUT NEW BITUMINOUS OR CONCRETE SURFACING SHALL BE SAWCUT TO OBTAIN A VERTICAL EDGE.
4. EXPANSION JOINTS SHALL BE PLACED AT ALL LOCATIONS WHERE NEW CONCRETE ABUTS EXISTING CONCRETE, AND AT ALL LOCATIONS WHERE SEPARATE CONCRETE POURS ABUT EACH OTHER.
5. CONCRETE PAVEMENT OR APRONS, WHICH ABUT DOORWAY OPENINGS SHALL BE TIED TO THE FLOOR SLAB WITH #4 BARS ALONG THE ENTIRE WIDTH OF THE DOORWAY. SEE DETAIL ON SHEET C2.
6. SEE SHEET C1 FOR SPECIFICATIONS REGARDING THE CONSTRUCTION OF PAVEMENTS, AND CURB AND GUTTER.



# City of Grant: Future Land Use and Zoning

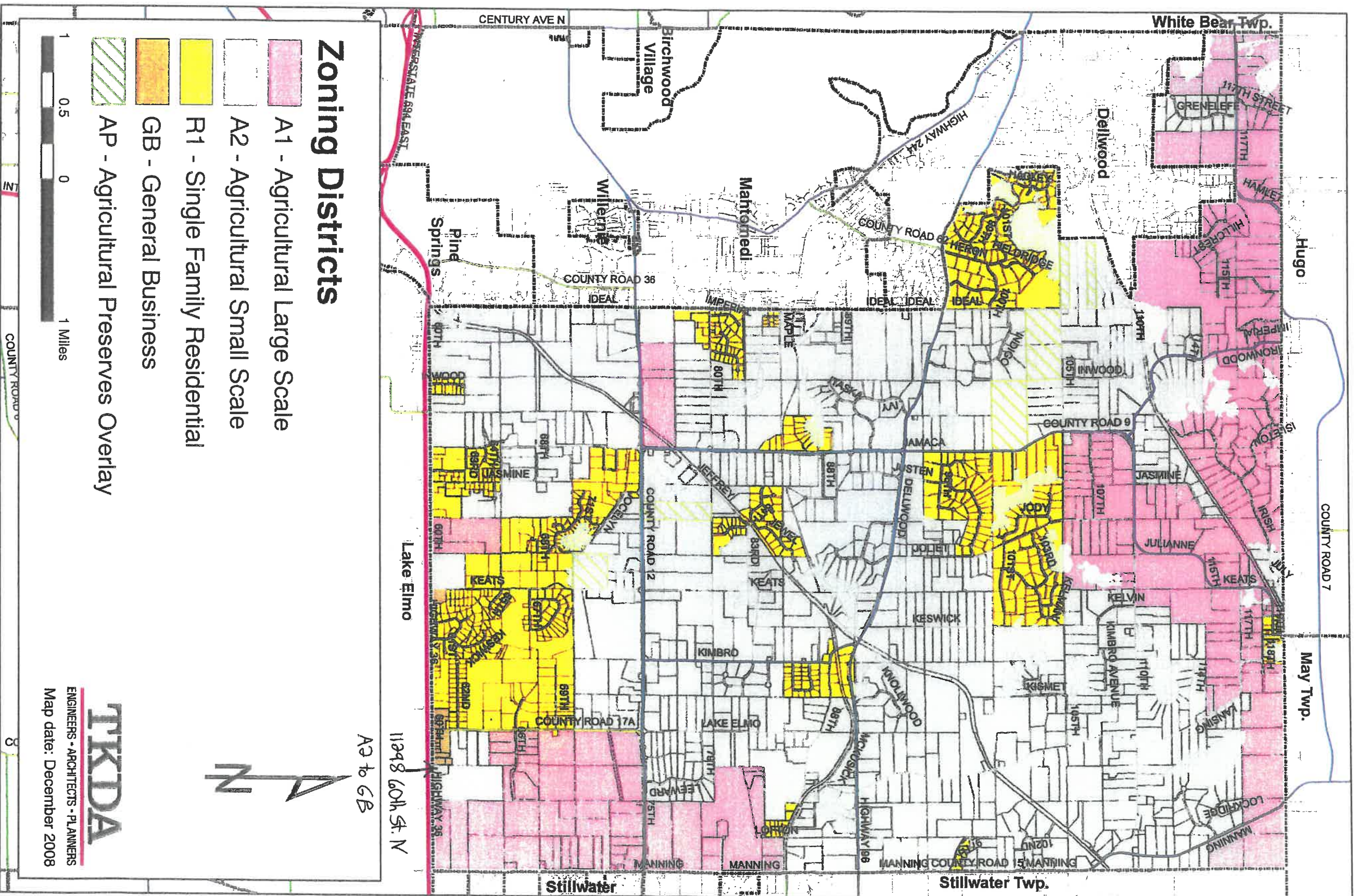

## Zoning Districts

- A1 - Agricultural Large Scale
- A2 - Agricultural Small Scale
- R1 - Single Family Residential
- GB - General Business
- AP - Agricultural Preserves Overlay



ENGINEERS - ARCHITECTS - PLANNERS  
Map date: December 2008

Source: Metropolitan Council, TKDA



# LOT LINE ADJUSTMENT

~for~ **JOSEPH INGEBRAND REAL ESTATE, LLC**  
 ~of~ **9980 & 10000 110th Street North**  
**Grant, Minnesota 55082**

**VICINITY MAP**  
 PART OF SEC. 2 & 3, TWP. 30, R. 21



PLN No. 02-030-21-14-0002  
 Owner: JOSEPH INGEBRAND REAL ESTATE, LLC  
 Address: 11000 110TH ST. N., STILLWATER, MN 55082

PLN No. 02-030-12-12-0001  
 Owner: JOSEPH INGEBRAND REAL ESTATE, LLC  
 Address: 11000 110TH ST. N., STILLWATER, MN 55082

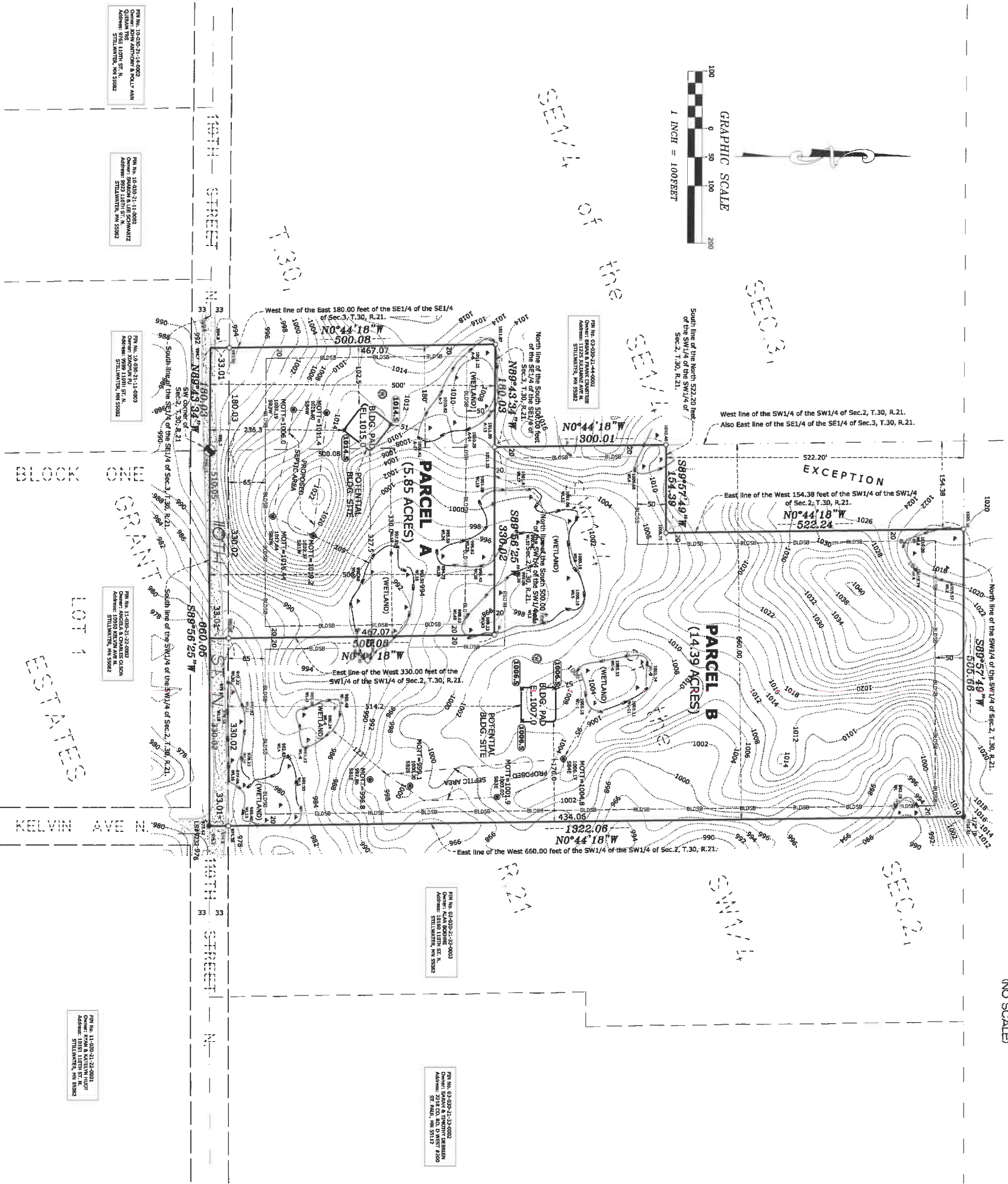
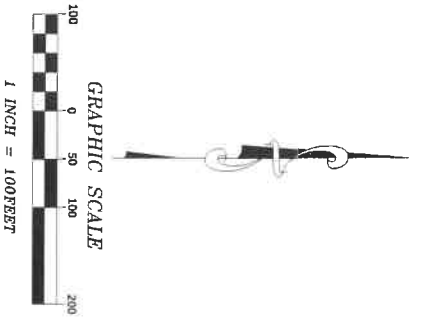

### EXISTING PROPERTY DESCRIPTION

The east 180.00 feet of the south 500.00 feet of the Southeast Quarter of Section 3, Township 30, Range 21, Washington County, Minnesota;  
 And  
 The west 660.00 feet of the Southwest Quarter of the Southwest Quarter of Section 2, Township 30, Range 21, Washington County, Minnesota, EXCEPT the north 522.20 feet of the west 154.38 feet thereof;

### PROPOSED PROPERTY DESCRIPTION

**PARCEL A:**  
 The east 180.00 feet of the south 500.00 feet of the Southeast Quarter of Section 3, Township 30, Range 21, Washington County, Minnesota;  
 And  
 The west 330.00 feet of the south 500.00 feet of the Southwest Quarter of Section 2, Township 30, Range 21, Washington County, Minnesota;

**PARCEL B:**  
 The west 660.00 feet of the Southwest Quarter of the Southwest Quarter of Section 2, Township 30, Range 21, Washington County, Minnesota, EXCEPT the north 522.20 feet of the west 154.38 feet thereof, and EXCEPT the west 330.00 feet of the south 500.00 feet thereof;

### NOTES

- Field survey was completed by E.G. Ridd and Sons, Inc. on 11/21/19.
- Bearings shown are on Washington County datum.
- Parcel ID Number: 02-030-21-33-0004.
- Total Parcel Area = 20.24 Acres
- Property is Zoned: A-1 (Agricultural Large Scale)
- Minimum Building Setbacks: 69 feet Front Yard  
20 feet Side Yard  
50 feet Rear Yard
- Wetland Delineation conducted by Travis Pristed (Certification #1169) on 11-4-2019.

### BENCHMARK

NGS STATION: LACROIXIN  
 ELEVATION = 1044.588 (N.A.V.D. 1989)

### LEGEND

- DENOTES IRON MONUMENT FOUND AS LABELED
- DENOTES IRON MONUMENT SET, MARKED RLS# 41578
- DENOTES WASHINGTON COUNTY CAST IRON MONUMENT
- DENOTES SOIL BORING (COMPLETED BY KSD, LLC)
- DENOTES PROPOSED WELL LOCATION
- DENOTES BUILDING SETBACK LINE
- DENOTES WETLAND
- DENOTES PROPOSED ELEVATION
- DENOTES EXISTING SPOT ELEVATION
- DENOTES LIAR CONTOURS
- DENOTES DELINEATED WETLAND BOUNDARY
- DENOTES GRAVEL SURFACE
- DENOTES ADJACENT PARCEL, OWNER, INFORMATION (PER WASHINGTON COUNTY TAX INFORMATION)

### PARCEL A BUILDABLE AREA

(SLOPES LESS THAN 25%)  
 TOTAL PARCEL AREA: 294,825 SQ. FT. OR 3.89 ACRES  
 LESS BUILDING SETBACKS: 99,792 SQ. FT.  
 LESS SLOPES GREATER THAN 25%: 14,066 SQ. FT.  
 LESS DELINEATED WETLANDS: 22,344 SQ. FT.  
 TOTAL BUILDABLE AREA: 128,437 SQ. FT. 2.89 ACRES

### PARCEL B BUILDABLE AREA

(SLOPES LESS THAN 25%)  
 TOTAL PARCEL AREA: 626,828 SQ. FT. OR 14.39 ACRES  
 LESS BUILDING SETBACKS: 118,387 SQ. FT.  
 LESS SLOPES GREATER THAN 25%: 14,066 SQ. FT.  
 LESS DELINEATED WETLANDS: 52,798 SQ. FT.  
 TOTAL BUILDABLE AREA: 441,619 SQ. FT. 10.14 ACRES

**E.G. RIDD & SONS, INC.**  
 Professional Land Surveyors  
 6776 Lake Drive NE, Suite 110  
 Lino Lakes, MN 55014  
 Tel: (651) 361-8200 Fax (651) 361-8701

**JASON E. RIDD**  
 Date: August 24, 2020 License No. 41578

I hereby certify that this survey, plan or report was prepared by me or under my direct supervision and that I am a duly registered Land Surveyor under the laws of the State of Minnesota.

DRAWN BY: CT	JOB NO: 199218T	DATE: 08/24/20
CHECK BY: JER	FIELD CREW: DT/CT	
1		
2		
3		
NO.	DATE	DESCRIPTION
BY		